

# Beautifully designed insurance



# Beautifully designed insurance

At Beazley, our commitment is to deliver beautifully designed insurance to our clients around the world.

Beautiful designs require beautifully designed insurance. Our architects' and engineers' professional indemnity team is just one of the many teams at Beazley that work closely with brokers to design customised insurance, backed by expert service, to address our clients' most pressing needs. We are proud to have insured the architects behind the Jeddah Tower and many other pioneering designs, Adrian Smith + Gordon Gill Architecture, since 2008 and the building's structural engineers, Thornton Tomasetti, since 2006.

When complete in 2020, the Jeddah Tower will be the world's tallest building, soaring more than a kilometre (3,281 feet) above Jeddah, a Red Sea port and Saudi Arabia's second largest city.



Artist's impression of Jeddah Tower.  
Design architect: Adrian Smith +  
Gordon Gill Architecture

## Contents

1	Highlights and key performance indicators	11	Condensed consolidated statement of changes in equity	36	Independent review report to Beazley plc
3	Interim results statement	12	Condensed consolidated statement of financial position	37	Glossary
6	31 years of profitable growth	13	Condensed consolidated statement of cash flows	40	Company information
8	Performance by division	14	Notes to the condensed consolidated interim financial statements		
10	Condensed consolidated statement of profit or loss	35	Responsibility statement of the directors in respect of the interim report		
11	Condensed consolidated statement of comprehensive income				

# About Beazley

Beazley plc is the parent company of our specialist insurance business with operations in Europe, North America, Latin America, Asia and the Middle East. Beazley is a proud participant in the Lloyd's market, one of the largest and oldest insurance markets in the world. Through the Lloyd's broker network and the market's trading licences, we are able to access a wide range of insurance and reinsurance business from around the world. Many of the lines of business we underwrite, such as marine and energy, political risks and contingency, were pioneered at Lloyd's.

Beazley manages six Lloyd's syndicates: syndicates 2623 and 623 underwrite a broad range of insurance and reinsurance business worldwide; syndicate 3623 focuses on personal accident and sport business along with providing reinsurance to Beazley Insurance Company, Inc. in the US; 3622 is a

dedicated life syndicate; 6107, a special purpose syndicate, which writes reinsurance business; and 6050, another special purpose syndicate, which reinsures syndicates 623 and 2623.

We also underwrite business directly in the US admitted market through Beazley Insurance Company, Inc., an admitted carrier licensed to write in all 50 states.

In 2009 we incorporated an Irish reinsurer, Beazley Re Designated Activity Company (dac), which reinsures a proportion of the group's business. In June 2017, Beazley Re dac became Beazley Insurance dac after receiving a licence to transact insurance business.

Further information about us is available at: [www.beazley.com](http://www.beazley.com)

## Highlights and key performance indicators

Continued growth and increased profit

### Highlights

	6 months 2017	6 months 2016	Full year 2016
Gross premiums written (\$m)	1,149.3	1,124.1	2,195.6
Net premiums written (\$m)	936.4	930.4	1,854.0
Net earned premiums (\$m)	886.7	861.4	1,768.2
Profit before income tax (\$m)	158.7	150.2	293.2
Claims ratio	49%	51%	48%
Expense ratio	41%	39%	41%
Combined ratio	90%	90%	89%
Basic earnings per share (cents)	25.3	25.1	48.6
Net assets per share (cents)	289.3	267.0	286.8
Net tangible assets per share (cents)	264.8	249.6	268.2
Basic earnings per share (pence)	20.2	17.3	35.5
Net assets per share (pence)	226.0	199.3	225.9
Net tangible assets per share (pence)	206.9	186.3	211.2
Proposed dividend per share (pence)	3.7	3.5	20.5
Return on equity (annualised)	18%	19%	18%
Premium renewal rate change	(2%)	(2%)	(2%)
Investment return (annualised)	3.4%	2.8%	2.0%

KPIs

Financial highlights

Earnings per share (c)

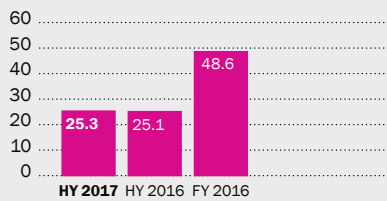

Net assets per share (c)

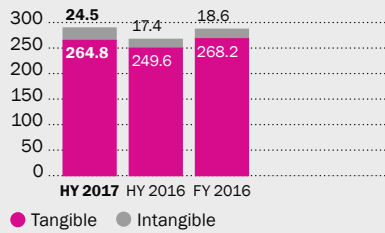

Gross premiums written (\$m)

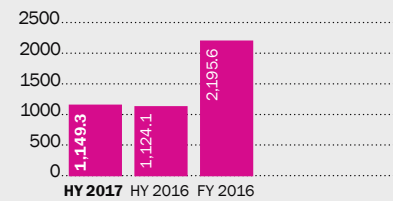

Dividends per share (p)

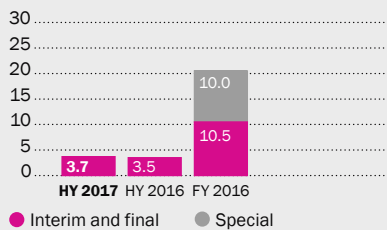

Return on equity (%)

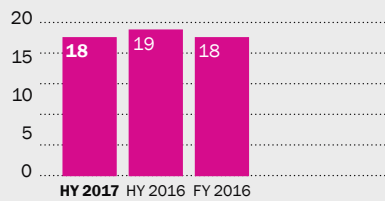

Combined ratio (%)

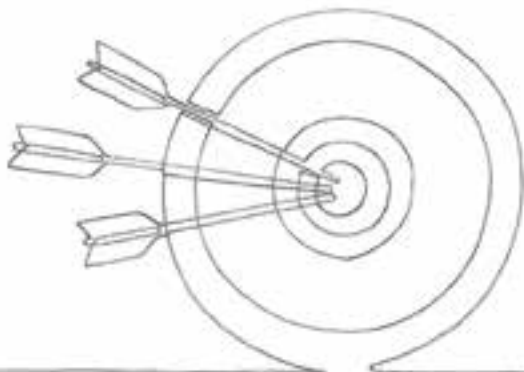
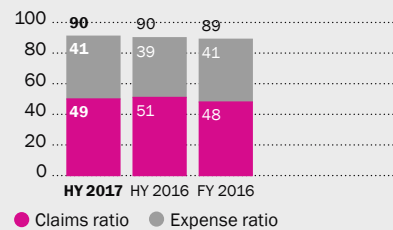

# Interim results statement



Andrew Horton  
Chief executive

We are pleased to deliver rising profits in an environment that remains challenging

Highlights and interim results

Beazley performed well during the first half of 2017, with a strong underwriting result boosted by an excellent investment return. Pre-tax profits rose 6% to \$158.7m (2016: \$150.2m) on gross premiums that, at \$1,149.3m, were 2% higher than for the comparable period last year (2016: \$1,124.1m). Our combined ratio was 90% (2016: 90%).

With market conditions for large, catastrophe exposed risks continuing to deteriorate, our specialty lines division, which is less focused on such risks, has been growing as a proportion of our underwriting portfolio. Specialty lines is itself a very diversified book, comprising professional liability, management liability, and environmental business – as well as our market-leading cyber insurance practice.

Most of our specialty lines clients are currently located in the US with large risks frequently underwritten in London and smaller risks commonly underwritten locally in the US. Our other divisions are also represented in the US, although on a smaller scale. We saw locally underwritten US premiums grow 9% in the first half of the year, relative to the same period last year.

We have also been laying the foundations for future growth elsewhere. In February we expanded our presence in Canada with the acquisition of the specialist managing general agent, Creechurch International Underwriters Limited (now Beazley Canada Limited). We have also continued to hire underwriters in Europe, Singapore and Miami: the latter two locations are now well recognised regional hubs for Asian and Latin American business respectively. These investments in the future of the business have led to an increased expense ratio, but we remain focused on managing costs actively in order to minimise such effects.

Continental Europe currently accounts for just over 5% of our total business, but we have growth ambitions there too, supported by the establishment of a new Dublin-based insurance company and by the measures Lloyd's is taking to preserve the market's access to European business following Britain's future departure from the European Union. We were therefore pleased to receive approval from the Central Bank of Ireland for our Irish-domiciled reinsurance company, Beazley Re dac, to transact insurance. To that end the company has been renamed Beazley Insurance dac.

Earlier, in March, Lloyd's announced plans to establish a new Brussels-based insurance company capable of writing European business for the 1 January 2019 renewal season, subject to regulatory approval. We should accordingly be able to grow our presence in Europe unimpeded, offering clients the specialist products and service we know they value.

Despite our continued success in generating strong underwriting profits, conditions for many of our underwriters remain exceptionally difficult. Premium rates for our business as a whole decreased by 2% but this masked steep declines for war (8%), energy (9%) and terrorism (11%). Rates for these lines of business have been falling steadily for several years. Our underwriters continue to succeed in writing profitable business against the backdrop of ever more challenging conditions, particularly in the marine market, but they are having to walk away from underpriced business with increasing frequency.

For as long as current market conditions prevail we expect growth opportunities for our London underwriters, who often specialise in catastrophe exposed risks, to be limited. By contrast, we continue to see attractive growth opportunities across our specialty lines portfolio. Demand continues for high quality cyber insurance, a market in which Beazley is very well known. Regulations concerning the handling of data breaches are tightening: the long awaited General Data Protection Regulation will come into force across the European Union next spring. Also, illustrations of why companies need to have protection continue, most recently with the internationally coordinated WannaCry malware attacks.

Together these trends continue to drive demand for cyber insurance among businesses of all sizes. Beazley is well equipped to meet this demand. Our Beazley Breach Response product is adapted to the needs of small and mid-sized businesses and Vector, our partnership with Munich Re, helps the world's largest companies build the substantial towers of insurance they are now seeking.

When underwriting cyber insurance we recognise the potential for systemic events, as we do in areas exposed to natural catastrophes, and seek to limit our aggregate exposure as well as purchasing substantial reinsurance. In cyber, as in other business areas, our risk management team, led by Andrew Pryde, works closely with our underwriters to monitor and manage aggregation risk.

## Interim results statement *continued*

### Cumulative renewal rate changes since 2008 (%)

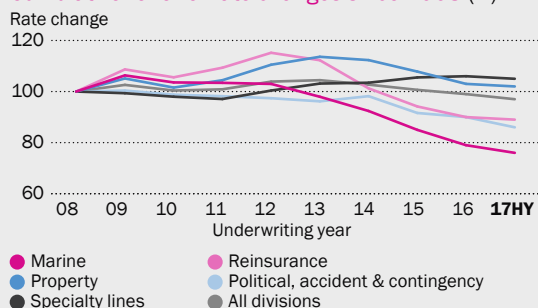

### Investments – portfolio split

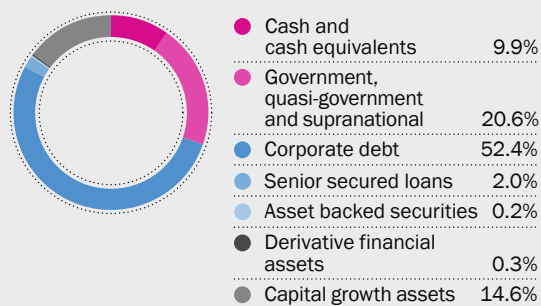

Other growth markets for Beazley in the first half, and areas in which we see continuing strong potential, were healthcare risks and environmental risks. Healthcare expenditures account for nearly 18% of the US economy and the market is constantly evolving, generating new risks for healthcare providers. Earlier this year, our US healthcare team launched Beazley Virtual Care, a pioneering insurance policy to cover organisations involved in the provision of telemedicine, a fast growing sector of the healthcare market.

Outside the US, financial institutions business is another market that we see as offering strong growth potential for our specialty lines underwriters. In May we launched a new package product in London for financial institutions, combining crime and professional indemnity cover with Beazley's data breach capability. We have also opened a new office in Barcelona and our hiring plans for the underwriters who will write business for the newly formed Beazley Insurance dac across Europe are well advanced.

Not all markets offer equal promise of course. In May we sold the renewal rights to our Australian accident and health business to Blend Insurance Solutions, a Sydney-based Lloyd's service company. We will continue to focus on the growth of our accident and health business in London as well as in the US where, in May, we welcomed Brian Thompson to lead our US A&H team. These measures should enable us to improve the combined ratio of the team which has been higher than planned.

The divisional structure of Beazley also changed in the first half of the year, spurred by the decision of Adrian Lewers, head of our political risks and contingency division, to retire from the business. This division has now been merged with our life, accident & health division under the leadership of Christian Tolle. My colleagues and I are enormously grateful to Adrian for his many contributions to Beazley, not least the creation of three successful specialist underwriting teams focusing on political, terrorism and contingency risks.

Our recruitment and business development efforts around the world continue to be supported by the strength of the Beazley brand within our markets. We have largely grown organically, with rare exceptions for relatively small scale acquisitions of firms, such as Creechurch, that we know well and with which we have long term relationships. The success of this strategy has fostered Beazley's reputation across our industry as an

entrepreneurial company where talented individuals can build rewarding long term careers. At times of market dislocation, such as we have recently seen, this makes us a magnet for talent.

Although talent is a necessary condition for success in today's insurance markets, we are well aware that it is not a sufficient condition. The way in which insurers amass and interpret data, to support underwriting and enhance customer service, is also of critical importance. Our chief operating officer, Ian Fantozzi, has been leading our newly established data and analytics strategic initiative to ensure that Beazley is a beneficiary of the exciting developments in this arena.

### Investment performance

Our investments returned \$79.4m, or 1.7% in the first half of 2017 (30 June 2016: \$62.7m, 1.4%). Investments have been volatile in this period, largely as a result of political uncertainty in the US. Overall however, US sovereign yields are little changed from the beginning of the year whilst credit spreads have continued to narrow and equity markets have risen strongly, reflecting underlying optimism about global economic prospects. As a result, our return in the year to date is higher than we had anticipated, helped by the shift from sovereign to corporate bond investments that we made in 2016 as well as modest additions to our equity exposures in 2016 and 2017. However, 'risk' assets have been rallying for an extended period and are increasingly vulnerable to disappointing economic news.

The breakdown of our investment portfolio at 30 June 2017 was:

	30 June 2017 \$m	30 June 2017 %	30 June 2016 \$m	30 June 2016 %
Cash and cash equivalents	461.4	9.9	441.8	10.0
Fixed and floating rate debt securities				
– Government, quasi-government and supranational	955.0	20.6	1,293.0	29.4
– Asset backed securities	11.3	0.2	3.6	0.1
– Corporate bonds				
– Investment grade	2,322.1	50.1	1,928.8	43.9
– High yield	106.0	2.3	118.7	2.7
– Senior secured loans	91.3	2.0	83.3	1.9
Derivative financial assets	12.6	0.3	5.3	0.1
Core portfolio	3,959.7	85.4	3,874.5	88.1



	30 June 2017 \$m	30 June 2017 %	30 June 2016 \$m	30 June 2016 %
Equity linked funds	167.0	3.6	98.9	2.3
Hedge funds	344.0	7.4	295.4	6.7
Illiquid credit assets	168.4	3.6	125.8	2.9
Capital growth assets	679.4	14.6	520.1	11.9
<b>Investment portfolio total</b>	<b>4,639.1</b>	<b>100.0</b>	<b>4,394.6</b>	<b>100.0</b>

At 30 June 2017 the average duration of our fixed income portfolios was 2.0 years (31 December 2016: 1.2 years) and the average credit rating of these exposures was A.

### Investment return by asset type

Analysis of returns on the core portfolio and the capital growth assets are set out below:

	30 June 2017 \$m	30 June 2017 annualised return %	30 June 2016 \$m	30 June 2016 annualised return %
Core portfolio	44.2	2.2	60.0	3.1
Capital growth assets	35.2	10.4	2.7	1.0
<b>Overall return</b>	<b>79.4</b>	<b>3.4</b>	<b>62.7</b>	<b>2.8</b>

The increased return on capital growth assets is driven by: a much improved return from equities compared to the first six months of 2016 on a larger portfolio; and an increasing return on the illiquid credit assets as this portfolio matures.

### Capital position

Our funding comes from a mixture of our own equity (on a Solvency II basis) alongside \$248.4m of tier 2 subordinated debt, \$18.0m of subordinated long term debt and a \$95.5m retail bond. We also have an undrawn banking facility of \$225.0m.

The following table sets out the group's sources of funds:

	30 June 2017 \$m	30 June 2016 \$m
Shareholders' funds	1,506.1	1,379.2
Tier 2 subordinated debt (2026) – recalled in 2016	–	103.0
Tier 2 subordinated debt (2026) – issued in 2016	248.4	–
Retail bond (2019)	95.5	99.8
Long term subordinated debt (2034)	18.0	18.0
<b>Total</b>	<b>1,868.0</b>	<b>1,600.0</b>

Our specialty lines business is likely to play a larger role in driving our capital requirements in the future as it is becoming a larger percentage of the total, thanks to its own growth, and because we continue to reduce our peak natural catastrophe exposure to reflect the rating environment. As a consequence, we would expect the rate of growth of our Lloyd's ECR to be close to double digits over the next few years.

In November 2016 we issued \$250.0m of subordinated debt to facilitate this planned growth, and these funds remain available to meet our increasing capital requirement.

The following table sets out the group's capital requirement including a provisional projection based upon the first version of our 2018 business plan of the year end Lloyd's ECR which is 7% higher than the previous year.

	Projected 31 December 2017 \$m	31 December 2016 \$m
Lloyd's economic capital requirement (ECR)	1,590.0	1,489.2
Capital for US insurance company	107.7	107.7
<b>Total</b>	<b>1,697.7</b>	<b>1,596.9</b>

At 30 June 2017 we have surplus capital (on a Solvency II basis) of 31% of the projected year end ECR.

### Dividend

The board has declared a first interim dividend of 3.7 pence (2016: 3.5 pence), in line with our strategy of delivering 5-10% dividend growth. This will be paid on 31 August 2017 to shareholders on the register at 5.00pm on 4 August 2017.

### Outlook

For most insurers, current market conditions are not conducive to growth. For some, any growth at all is proving elusive. I believe that Beazley can continue to grow in the mid single digits while generating underwriting profits. However in the absence of any market-turning catastrophe events (which would of course generate sizeable short term losses), the challenge of achieving this growth will increase.

Our priorities in this environment are clear. We will not sacrifice profitability for growth, which means that we will continue to walk away from underpriced business. We will also continue to invest in the skills and infrastructure needed to succeed in any rating environment.

We hired 29 people in the first half of the year to fill newly created underwriting roles but this was just one facet of our investment in the future of our business. It takes many skills to compete effectively in a crowded insurance market that is awash with capacity and targeted by numerous would-be disrupters. To meet both short term and long term challenges, we will continue to invest broadly in talent from inside and outside our industry.

**Andrew Horton**  
Chief executive

20 July 2017

# 31 years of profitable growth

Beazley's vision is to become, and be recognised as, the highest performing specialist insurer

2007	2008	2009	2010	2011
\$1,919.6m Managed gross premiums	\$1,984.9m Managed gross premiums	\$2,121.7m Managed gross premiums	\$2,108.5m Managed gross premiums	\$2,079.2m Managed gross premiums
\$1,561.0m Group share	\$1,620.0m Group share	\$1,751.3m Group share	\$1,741.6m Group share	\$1,712.5m Group share
	<ul style="list-style-type: none"> <li>Beazley opens new office in Munich</li> <li>Political risks &amp; contingency group formed as new division</li> <li>Acquisition of Momentum Underwriting Management</li> <li>Accident &amp; life formed as a new division</li> <li>US hurricane Ike \$20bn</li> </ul>	<ul style="list-style-type: none"> <li>Raised £150m through rights issue to develop our business at Lloyd's and in the US</li> <li>Acquisition of First State Management Group, Inc., a US underwriting manager focusing on surplus lines commercial property business</li> <li>Beazley plc becomes the new holding company for the group, incorporated in Jersey and tax-resident in Ireland</li> </ul>	<ul style="list-style-type: none"> <li>Andrew Beazley, co-founder of Beazley Group and chief executive until September 2008, dies at the age of 57</li> <li>Beazley changes functional and presentational currency to US dollar</li> <li>Beazley opens new office in Oslo</li> <li>Special purpose syndicate 6107 formed to grow reinsurance business</li> <li>Chile and NZ earthquakes \$14bn</li> <li>Deepwater Horizon explosion triggers biggest oil spill in history</li> </ul>	<ul style="list-style-type: none"> <li>Expansion of Australian accident &amp; health business through acquisition of two MGAs</li> <li>Launch of the Andrew Beazley Broker Academy</li> <li>Nick Furlonge, co-founder, retires as an executive member but becomes a non-executive of Beazley Furlonge Limited</li> <li>Beazley remains profitable in worst year ever for insured natural catastrophe losses</li> <li>Tohoku earthquake in Japan \$37bn</li> <li>Floods in Thailand \$16bn</li> <li>US tornadoes \$15bn</li> <li>NZ earthquake \$16bn</li> </ul>

1986	1991	1992	1997
\$13.4m Managed gross premiums	\$42.5m Managed gross premiums	\$58.8m Managed gross premiums	\$128.4m Managed gross premiums
<ul style="list-style-type: none"> <li>Began trading at the 'old' 1958 Lloyd's building in 1986 with a capacity of £8.3m</li> <li>Beazley, Furlonge &amp; Hiscox established and takes over managing syndicate 623</li> <li>Specialty lines and treaty accounts started</li> <li>UK windstorms \$3.5bn</li> <li>European storms \$10bn</li> </ul>		<ul style="list-style-type: none"> <li>Management buyout of Hiscox share</li> <li>Commercial property account started</li> <li>Corporate capital introduced at Lloyd's followed by Lloyd's Reconstruction and Renewal</li> <li>APUA, based in Hong Kong, forms a strategic partnership with Beazley Furlonge</li> <li>US hurricane Andrew \$17bn</li> <li>UK Bishopsgate explosion \$750m</li> <li>US Northridge earthquake \$12.5bn</li> </ul>	





## Beazley began life in 1986

Since then, we have grown steadily in terms of the risks we cover, the clients we serve and our geographic reach, and today Beazley is a mature insurance business with a well-diversified portfolio. While we have weathered some of the toughest times the Lloyd's market has seen in more than three centuries, our underwriting operations continue to maintain a strong record of profitability.

2012

\$2,278.0m

Managed gross premiums

\$1,895.9m

Group share

Expansion into aviation and kidnap & ransom markets

Reinsurance division broadens access to South East Asia, China and South Korea business with local presence in Singapore

Political risks & contingency expands into French market

Superstorm Sandy \$25-30bn

2013

\$2,373.0m

Managed gross premiums

\$1,970.2m

Group share

Construction Consortium launched at Lloyd's

Miami office opened to access Latin American reinsurance business

Beazley Flight – comprehensive emergency evacuation cover – launched

Beazley data breach cover extended in Europe. 1,000th breach managed

Local representation added in Rio to develop Latin American insurance business

2014

\$2,424.7m

Managed gross premiums

\$2,021.8m

Group share

Construction Consortium extended to Lloyd's Asia

Middle East office opened to access local political risk and violence, terrorism, trade credit and contingency business

Space and satellite insurance account started

D&O Consortium launched at Lloyd's

Locally underwritten US business grows 19% to \$537m

2015

\$2,525.6m

Managed gross premiums

\$2,080.9m

Group share

Entered into a reinsurance agreement with Korean Re

US underwritten premium grows by 21%

Cyber consortium launched at Lloyd's

Beazley welcomes its 1,000th employee globally

2016

\$2,666.5m

Managed gross premiums

\$2,195.6m

Group share

Beazley celebrated its 30th anniversary

10th anniversary of operations in Singapore and Paris

Beazley plc becomes the new holding company for the group, incorporated in England & Wales and tax-resident in the United Kingdom

Established a partnership with Munich Re to broaden and enhance the cyber cover available to the world's largest companies

## Versatile specialists since 1986

1998

\$168.8m

Managed gross premiums

Recall, contingency and political risks accounts started

Marine account started

European storms \$12bn

2000

\$256.1m

Managed gross premiums

2001

\$431.6m

Managed gross premiums

Management buyout of minority shareholders

EPL and UK PI accounts started

Flotation raised £150m to set up Beazley Group plc

D&O healthcare, energy, cargo and specie accounts started

Established local representation in the US

Beazley MGA started in the US

Beazley acquires Omaha P&C and renames it Beazley Insurance Company, Inc. (BICI)

Beazley expands presence in Asia and Europe

US 9/11 terrorist attack \$20.3bn

SARS outbreak in Asia \$3.5bn

US hurricanes Katrina, Rita and Wilma \$101bn

2006

\$1,762.0m

Managed gross premiums



# Performance by division

Good performance despite declining rates

## Marine



Clive Washbourn  
Head of marine

### Combined ratio (%)

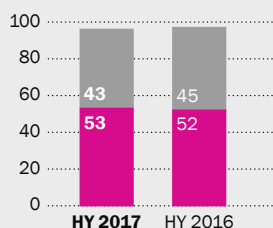

● Claims ratio ● Expense ratio

	2017 \$m	2016 \$m
Gross premiums written	145.6	134.0
Net premiums written	118.9	107.9
Results from operating activities	10.9	9.4
Claims ratio	53%	52%
Expense ratio	43%	45%
Combined ratio	96%	97%
Rate change	(4%)	(7%)

## Political, accident & contingency



Christian Tolle  
Head of political, accident & contingency

### Combined ratio (%)

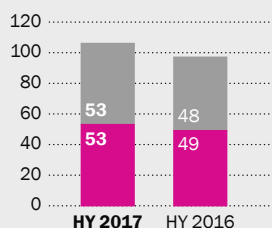

● Claims ratio ● Expense ratio

	2017 \$m	2016 \$m
Gross premiums written	108.4	149.3
Net premiums written	94.9	128.8
Results from operating activities	(0.6)	6.5
Claims ratio	53%	49%
Expense ratio	53%	48%
Combined ratio	106%	97%
Rate change	(5%)	(4%)

## Property



Mark Bernacki  
Head of property

### Combined ratio (%)

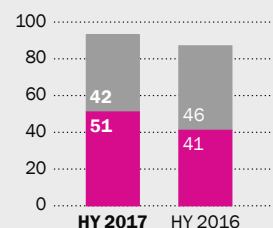

● Claims ratio ● Expense ratio

	2017 \$m	2016 \$m
Gross premiums written	194.1	173.0
Net premiums written	149.6	142.1
Results from operating activities	18.4	26.0
Claims ratio	51%	41%
Expense ratio	42%	46%
Combined ratio	93%	87%
Rate change	(1%)	(4%)



Neil Maidment  
Chief underwriting officer

## Reinsurance



Patrick Hartigan  
Head of reinsurance

### Combined ratio (%)

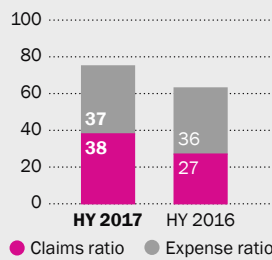

	2017 \$m	2016 \$m
Gross premiums written	140.8	150.2
Net premiums written	82.9	92.9
Results from operating activities	19.6	29.8
Claims ratio	38%	27%
Expense ratio	37%	36%
Combined ratio	75%	63%
Rate change	(2%)	(4%)

## Specialty lines



Adrian Cox  
Head of specialty lines

### Combined ratio (%)

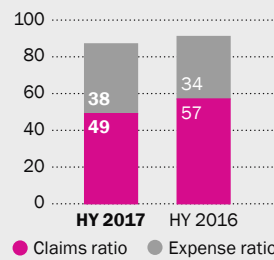

	2017 \$m	2016 \$m
Gross premiums written	560.4	517.6
Net premiums written	490.1	458.7
Results from operating activities	121.3	85.8
Claims ratio	49%	57%
Expense ratio	38%	34%
Combined ratio	87%	91%
Rate change	(1%)	1%



# Condensed consolidated statement of profit or loss

for the six months ended 30 June 2017

	Note	6 months ended 30 June 2017 \$m	6 months ended 30 June 2016 \$m	Year to 31 December 2016 \$m
Gross premiums written	2	1,149.3	1,124.1	2,195.6
Written premiums ceded to reinsurers		(212.9)	(193.7)	(341.6)
<b>Net premiums written</b>	2	<b>936.4</b>	<b>930.4</b>	<b>1,854.0</b>
Change in gross provision for unearned premiums		(100.1)	(103.5)	(83.4)
Reinsurer's share of change in the provision for unearned premiums		50.4	34.5	(2.4)
<b>Change in net provision for unearned premiums</b>		<b>(49.7)</b>	<b>(69.0)</b>	<b>(85.8)</b>
<b>Net earned premiums</b>	2	<b>886.7</b>	<b>861.4</b>	<b>1,768.2</b>
Net investment income	3	79.4	62.7	93.1
Other income	4	17.0	15.8	32.7
		<b>96.4</b>	<b>78.5</b>	<b>125.8</b>
<b>Revenue</b>	2	<b>983.1</b>	<b>939.9</b>	<b>1,894.0</b>
Insurance claims		541.3	535.3	1,027.3
Insurance claims recovered from reinsurers		(102.4)	(99.1)	(171.7)
<b>Net insurance claims</b>	2,11	<b>438.9</b>	<b>436.2</b>	<b>855.6</b>
Expenses for the acquisition of insurance contracts		241.5	219.6	472.5
Administrative expenses		121.7	117.2	247.8
Foreign exchange loss	2	11.5	9.6	9.5
<b>Operating expenses</b>		<b>374.7</b>	<b>346.4</b>	<b>729.8</b>
<b>Expenses</b>	2	<b>813.6</b>	<b>782.6</b>	<b>1,585.4</b>
Share of profit/(loss) in associates	2	0.1	0.2	(0.2)
<b>Results of operating activities</b>		<b>169.6</b>	<b>157.5</b>	<b>308.4</b>
Finance costs	5	(10.9)	(7.3)	(15.2)
<b>Profit before income tax</b>		<b>158.7</b>	<b>150.2</b>	<b>293.2</b>
Income tax expense	8	(27.0)	(21.4)	(42.2)
<b>Profit after income tax – all attributable to equity shareholders</b>		<b>131.7</b>	<b>128.8</b>	<b>251.0</b>
<b>Earnings per share (cents per share):</b>				
Basic	6	25.3	25.1	48.6
Diluted	6	24.6	24.3	47.3
<b>Earnings per share (pence per share):</b>				
Basic	6	20.2	17.3	35.5
Diluted	6	19.7	16.8	34.5

# Condensed consolidated statement of comprehensive income

for the six months ended 30 June 2017

	6 months ended 30 June 2017 \$m	6 months ended 30 June 2016 \$m	Year to 31 December 2016 \$m
Profit after income tax	131.7	128.8	251.0
<b>Other comprehensive income</b>			
<i>Items that will never be reclassified to profit or loss:</i>			
Loss on remeasurement of retirement benefit obligations	-	-	(6.1)
<i>Items that may be reclassified subsequently to profit or loss:</i>			
Foreign currency translation differences	(0.8)	(5.6)	(10.1)
Total other comprehensive income	(0.8)	(5.6)	(16.2)
<b>Total comprehensive income recognised</b>	<b>130.9</b>	<b>123.2</b>	<b>234.8</b>

# Condensed consolidated statement of changes in equity

for the six months ended 30 June 2017

	Share capital \$m	Merger reserve \$m	Foreign currency translation reserve \$m	Other reserves \$m	Retained earnings \$m	Total \$m
<b>Balance as at 1 January 2016</b>	<b>666.7</b>	<b>(628.5)</b>	<b>(87.3)</b>	<b>6.7</b>	<b>1,483.8</b>	<b>1,441.4</b>
Total comprehensive income recognised	-	-	(5.6)	-	128.8	123.2
Dividends paid	-	-	-	-	(188.3)	(188.3)
Issue of shares <sup>1</sup>	2.5	(2.3)	-	-	-	0.2
Capital reduction <sup>2</sup>	(631.5)	630.8	0.7	-	-	-
Equity settled share-based payments	-	-	-	12.2	-	12.2
Acquisition of own shares held in trust	-	-	-	(9.7)	-	(9.7)
Transfer of shares to employees	-	-	-	(2.1)	2.3	0.2
<b>Balance as at 30 June 2016</b>	<b>37.7</b>	<b>-</b>	<b>(92.2)</b>	<b>7.1</b>	<b>1,426.6</b>	<b>1,379.2</b>
Total comprehensive income recognised	-	-	(4.5)	-	116.1	111.6
Dividends paid	-	-	-	-	(23.9)	(23.9)
Equity settled share-based payments	-	-	-	13.8	-	13.8
Acquisition of own shares held in trust	-	-	-	-	-	-
Tax on share option vestings	-	-	-	-	2.1	2.1
Transfer of shares to employees	-	-	-	2.5	(1.6)	0.9
<b>Balance as at 31 December 2016</b>	<b>37.7</b>	<b>-</b>	<b>(96.7)</b>	<b>23.4</b>	<b>1,519.3</b>	<b>1,483.7</b>
Total comprehensive income recognised	-	-	(0.8)	-	131.7	130.9
Dividends paid	-	-	-	-	(110.8)	(110.8)
Equity settled share-based payments	-	-	-	15.3	-	15.3
Issue of shares	0.1	-	-	-	-	0.1
Acquisition of own shares held in trust	-	-	-	(16.2)	-	(16.2)
Tax on share option vestings	-	-	-	3.2	-	3.2
Transfer of shares to employees	-	-	-	(7.7)	7.6	(0.1)
<b>Balance as at 30 June 2017</b>	<b>37.8</b>	<b>-</b>	<b>(97.5)</b>	<b>18.0</b>	<b>1,547.8</b>	<b>1,506.1</b>

1 During the first half of 2016, 1.9m new ordinary shares were issued, as well as 0.1m of preference shares prior to the scheme of arrangement.

2 The subsequent capital reduction involved a reduction in the nominal value of the shares in the new parent to 5 pence per share.

# Condensed consolidated statement of financial position

as at 30 June 2017

	Note	30 June 2017 \$m	30 June 2016 \$m	31 December 2016 \$m
<b>Assets</b>				
Intangible assets	15	127.1	89.8	96.6
Plant and equipment		5.4	4.5	5.4
Deferred tax asset		11.8	6.8	11.0
Investments in associates		10.0	10.2	9.9
Deferred acquisition costs		274.1	247.1	242.8
Reinsurance assets		1,153.3	1,136.6	1,082.1
Financial assets at fair value	9	4,177.7	3,952.8	4,195.4
Insurance receivables		868.6	881.7	794.7
Current income tax assets		4.7	10.0	17.0
Other receivables		81.6	39.8	46.4
Cash and cash equivalents	10	461.4	441.8	507.2
<b>Total assets</b>		<b>7,175.7</b>	<b>6,821.1</b>	<b>7,008.5</b>
<b>Equity</b>				
Share capital		37.8	37.7	37.7
Foreign currency translation reserve		(97.5)	(92.2)	(96.7)
Other reserves		18.0	7.1	23.4
Retained earnings		1,547.8	1,426.6	1,519.3
<b>Total equity</b>		<b>1,506.1</b>	<b>1,379.2</b>	<b>1,483.7</b>
<b>Liabilities</b>				
Insurance liabilities		4,802.4	4,704.1	4,657.7
Financial liabilities	9	380.2	232.4	363.8
Retirement benefit liability		5.0	0.6	6.2
Deferred tax liabilities		7.0	0.9	12.8
Other payables		475.0	503.9	484.3
<b>Total liabilities</b>		<b>5,669.6</b>	<b>5,441.9</b>	<b>5,524.8</b>
<b>Total equity and liabilities</b>		<b>7,175.7</b>	<b>6,821.1</b>	<b>7,008.5</b>

**D A Horton**  
*Chief executive*

**M L Bride**  
*Finance director*

20 July 2017



# Condensed consolidated statement of cash flows

for the six months ended 30 June 2017

	6 months ended 30 June 2017 \$m	6 months ended 30 June 2016 \$m	Year to 31 December 2016 \$m
<b>Cash flow from operating activities</b>			
<b>Profit before income tax</b>	<b>158.7</b>	<b>150.2</b>	<b>293.2</b>
Adjustments for:			
Amortisation of intangibles	6.2	2.1	5.3
Equity settled share based compensation	12.7	11.4	23.0
Net fair value gain on financial investments	(45.1)	(34.8)	(28.9)
Share of (profit)/loss in associates	(0.1)	(0.2)	0.2
Depreciation of plant and equipment	1.2	0.8	1.8
Impairment of reinsurance assets recognised/(written back)	0.7	-	(1.1)
Increase in insurance and other liabilities	150.6	143.0	72.4
Increase in insurance, reinsurance and other receivables	(181.8)	(194.1)	(59.3)
Increase in deferred acquisition costs	(31.3)	(20.9)	(16.6)
Financial income	(37.4)	(31.8)	(71.5)
Finance expense	10.9	7.3	15.2
Income tax paid	(17.9)	(20.0)	(39.8)
<b>Net cash from operating activities</b>	<b>27.4</b>	<b>13.0</b>	<b>193.9</b>
<b>Cash flow from investing activities</b>			
Purchase of plant and equipment	(1.2)	(1.1)	(2.9)
Expenditure on software development	(0.7)	(1.9)	(4.7)
Purchase of investments	(1,215.4)	(3,573.4)	(5,985.4)
Proceeds from sale of investments	1,272.8	3,501.6	5,666.0
Investment in associate	-	-	(0.1)
Cash acquired on sale of Australian accident and health business	0.8	-	-
Net cash spent in business combinations	(31.2)	-	(8.0)
Interest and dividends received	37.4	31.8	71.5
<b>Net cash from investing activities</b>	<b>62.5</b>	<b>(43.0)</b>	<b>(263.6)</b>
<b>Cash flow from financing activities</b>			
Acquisition of own shares in trust	(16.2)	(9.7)	(9.7)
Proceeds from issue of shares	-	0.3	-
Repayment of borrowings	-	-	(107.1)
Proceeds of debt issue	-	-	248.7
Interest paid	(10.9)	(7.3)	(15.2)
Dividends paid	(110.8)	(188.3)	(212.2)
<b>Net cash used in financing activities</b>	<b>(137.9)</b>	<b>(205.0)</b>	<b>(95.5)</b>
<b>Net decrease in cash and cash equivalents</b>	<b>(48.0)</b>	<b>(235.0)</b>	<b>(165.2)</b>
Cash and cash equivalents at beginning of period	507.2	676.9	676.9
Effect of exchange rate changes on cash and cash equivalents	2.2	(0.1)	(4.5)
<b>Cash and cash equivalents at end of period</b>	<b>461.4</b>	<b>441.8</b>	<b>507.2</b>

# Notes to the condensed consolidated interim financial statements

for the six months ended 30 June 2017

## 1 Statement of accounting policies

Beazley plc is a company incorporated in England and Wales and is resident for tax purposes in the United Kingdom. The condensed consolidated interim financial statements of the group for the six months ended 30 June 2017 comprise the parent company, its subsidiaries and the group's interest in associates.

The condensed consolidated interim financial statements have been prepared and approved by the directors in accordance with IAS 34 Interim Financial Reporting as adopted by the EU ('Adopted IFRS'). The condensed consolidated interim financial statements of Beazley plc have been prepared on a going concern basis. The directors of the company have a reasonable expectation that the group and the company have adequate resources to continue in operational existence for the foreseeable future. The principal risks and uncertainties faced by the group remain consistent with those risks and uncertainties discussed and disclosed on pages 52 to 57 of the group's 2016 annual report and accounts.

The preparation of condensed consolidated interim financial statements requires management to make judgements, estimates and assumptions that affect the application of accounting policies and the reported amounts of assets and liabilities, income and expenses. Actual results may differ from these estimates. The significant judgements made by management in applying the group's accounting policies and the key sources of estimation uncertainty were the same as those that applied to the consolidated financial statements as at, and for, the year ended 31 December 2016. As required by IFRS 13 (Fair Value Measurement) information relating to the fair value measurement of financial assets and liabilities is outlined in note 9 to the condensed consolidated interim financial statements.

The accounting policies applied in the condensed consolidated interim financial statements are the same as those applied in the group's consolidated financial statements for the year ended 31 December 2016. There have been no additional standards endorsed by the EU since the year ended 31 December 2016, thus no additional standards have been applied by the group.

The financial information included in this document does not comprise statutory financial statements within the meaning of Companies Act 2006.

### New holding company

On 13 April 2016, under a scheme of arrangement involving a share exchange with the members of Beazley Ireland Holdings plc, Beazley plc became the new holding company for the Beazley group.

For further details on this please refer to pages 135 and 136 of the group's 2016 annual report and accounts.

## 2 Segmental analysis

Segment information is presented in respect of reportable segments. This is based on the group's management and internal reporting structures and represents the level at which financial information is reported to the board, being the chief operating decision maker as defined in IFRS 8.

Finance costs and taxation have not been allocated to operating segments as these items are determined by group level factors and do not relate to operating performance.

	30 June 2017					
	Marine \$m	Political, accident & contingency <sup>1</sup> \$m	Property \$m	Reinsurance \$m	Specialty lines \$m	Total \$m
Gross premiums written	145.6	108.4	194.1	140.8	560.4	1,149.3
Net premiums written	118.9	94.9	149.6	82.9	490.1	936.4
Net earned premiums	114.0	91.5	147.6	55.6	478.0	886.7
Net investment income	7.1	4.0	8.0	5.6	54.7	79.4
Other income	0.7	2.1	2.4	0.6	11.2	17.0
<b>Revenue</b>	<b>121.8</b>	<b>97.6</b>	<b>158.0</b>	<b>61.8</b>	<b>543.9</b>	<b>983.1</b>
Net insurance claims	60.5	48.8	74.9	20.9	233.8	438.9
Expenses for the acquisition of insurance contracts	33.6	32.6	43.2	14.2	117.9	241.5
Administrative expenses	15.3	15.4	19.6	6.4	65.0	121.7
Foreign exchange loss	1.5	1.2	1.9	0.7	6.2	11.5
<b>Expenses</b>	<b>110.9</b>	<b>98.0</b>	<b>139.6</b>	<b>42.2</b>	<b>422.9</b>	<b>813.6</b>
Share of (loss)/profit in associates	-	(0.2)	-	-	0.3	0.1
<b>Segment result</b>	<b>10.9</b>	<b>(0.6)</b>	<b>18.4</b>	<b>19.6</b>	<b>121.3</b>	<b>169.6</b>
Finance costs						(10.9)
<b>Profit before income tax</b>						<b>158.7</b>
Income tax expense						(27.0)
<b>Profit after income tax</b>						<b>131.7</b>
Claims ratio	53%	53%	51%	38%	49%	49%
Expense ratio	43%	53%	42%	37%	38%	41%
Combined ratio	96%	106%	93%	75%	87%	90%
<b>Segment assets and liabilities</b>						
Segment assets	1,239.8	1,061.1	1,104.1	451.8	3,318.9	7,175.7
Segment liabilities	(899.0)	(913.2)	(887.1)	(264.6)	(2,705.7)	(5,669.6)
<b>Net assets</b>	<b>340.8</b>	<b>147.9</b>	<b>217.0</b>	<b>187.2</b>	<b>613.2</b>	<b>1,506.1</b>

1 During 2017, the life, accident and health division and political risks and contingency division were combined to form the political, accident and contingency division. Comparative figures for 30 June 2016 and 31 December 2016 have been re-presented to reflect this change in structure and allow comparability.

## Notes to the interim financial statements *continued*

### 2 Segmental analysis *continued*

30 June 2016

	Marine \$m	Political, accident & contingency <sup>1</sup> \$m	Property \$m	Reinsurance \$m	Specialty lines \$m	Total \$m
Gross premiums written	134.0	149.3	173.0	150.2	517.6	1,124.1
Net premiums written	107.9	128.8	142.1	92.9	458.7	930.4
Net earned premiums	110.7	103.2	144.1	63.9	439.5	861.4
Net investment income	5.6	3.9	6.7	4.4	42.1	62.7
Other income	1.2	1.2	2.9	3.1	7.4	15.8
<b>Revenue</b>	<b>117.5</b>	<b>108.3</b>	<b>153.7</b>	<b>71.4</b>	<b>489.0</b>	<b>939.9</b>
Net insurance claims	56.9	51.1	59.7	17.5	251.0	436.2
Expenses for the acquisition of insurance contracts	32.1	32.0	43.8	16.0	95.7	219.6
Administrative expenses	18.0	17.5	22.7	7.1	51.9	117.2
Foreign exchange loss	1.1	1.3	1.5	1.0	4.7	9.6
<b>Expenses</b>	<b>108.1</b>	<b>101.9</b>	<b>127.7</b>	<b>41.6</b>	<b>403.3</b>	<b>782.6</b>
Share of profit in associates	-	0.1	-	-	0.1	0.2
<b>Segment result</b>	<b>9.4</b>	<b>6.5</b>	<b>26.0</b>	<b>29.8</b>	<b>85.8</b>	<b>157.5</b>
Finance costs						(7.3)
<b>Profit before income tax</b>						<b>150.2</b>
Income tax expense						(21.4)
<b>Profit after income tax</b>						<b>128.8</b>
Claims ratio	52%	49%	41%	27%	57%	51%
Expense ratio	45%	48%	46%	36%	34%	39%
Combined ratio	97%	97%	87%	63%	91%	90%
<b>Segment assets and liabilities</b>						
Segment assets	1,153.1	1,026.1	1,063.0	411.3	3,167.6	6,821.1
Segment liabilities	(804.9)	(872.6)	(849.3)	(247.9)	(2,667.2)	(5,441.9)
<b>Net assets</b>	<b>348.2</b>	<b>153.5</b>	<b>213.7</b>	<b>163.4</b>	<b>500.4</b>	<b>1,379.2</b>

1 During 2017, the life, accident and health division and political risks and contingency division were combined to form the political, accident and contingency division. Comparative figures for 30 June 2016 and 31 December 2016 have been re-presented to reflect this change in structure and allow comparability.

## 2 Segmental analysis *continued*

	31 December 2016					
	Marine \$m	Political, accident & contingency <sup>1</sup> \$m	Property \$m	Reinsurance \$m	Specialty lines \$m	Total \$m
Gross premiums written	247.4	245.3	329.7	213.4	1,159.8	2,195.6
Net premiums written	220.7	215.6	277.1	141.2	999.4	1,854.0
Net earned premiums	223.2	221.1	287.0	138.4	898.5	1,768.2
Net investment income	8.9	4.9	10.2	6.4	62.7	93.1
Other income	3.8	2.9	6.4	6.2	13.4	32.7
<b>Revenue</b>	<b>235.9</b>	<b>228.9</b>	<b>303.6</b>	<b>151.0</b>	<b>974.6</b>	<b>1,894.0</b>
Net insurance claims	98.9	99.7	115.3	40.2	501.5	855.6
Expenses for the acquisition of insurance contracts	65.9	67.1	88.8	34.7	216.0	472.5
Administrative expenses	35.5	33.4	46.6	14.5	117.8	247.8
Foreign exchange loss	1.1	1.1	1.4	0.7	5.2	9.5
<b>Expenses</b>	<b>201.4</b>	<b>201.3</b>	<b>252.1</b>	<b>90.1</b>	<b>840.5</b>	<b>1,585.4</b>
Share of loss in associates	-	-	-	-	(0.2)	(0.2)
<b>Segment result</b>	<b>34.5</b>	<b>27.6</b>	<b>51.5</b>	<b>60.9</b>	<b>133.9</b>	<b>308.4</b>
Finance costs						(15.2)
<b>Profit before income tax</b>						<b>293.2</b>
Income tax expense						(42.2)
<b>Profit after income tax</b>						<b>251.0</b>
Claims ratio	44%	45%	40%	29%	56%	48%
Expense ratio	46%	46%	47%	36%	37%	41%
Combined ratio	90%	91%	87%	65%	93%	89%
<b>Segment assets and liabilities</b>						
Segment assets	1,203.2	1,052.2	1,086.5	431.7	3,234.9	7,008.5
Segment liabilities	(840.2)	(880.1)	(859.3)	(245.4)	(2,699.8)	(5,524.8)
<b>Net assets</b>	<b>363.0</b>	<b>172.1</b>	<b>227.2</b>	<b>186.3</b>	<b>535.1</b>	<b>1,483.7</b>

1 During 2017, the life, accident and health division and political risks and contingency division were combined to form the political, accident and contingency division. Comparative figures for 30 June 2016 and 31 December 2016 have been re-presented to reflect this change in structure and allow comparability.

## Notes to the interim financial statements *continued*

### 3 Net investment income

	6 months ended 30 June 2017 \$m	6 months ended 30 June 2016 \$m	Year to 31 December 2016 \$m
Interest and dividends on financial investments at fair value through profit or loss	37.2	31.5	70.9
Interest on cash and cash equivalents	0.2	0.3	0.6
Net realised gains/(losses) on financial investments at fair value through profit or loss	5.4	(4.0)	(4.9)
Net unrealised fair value gains on financial investments at fair value through profit or loss	39.7	38.8	33.8
<b>Investment income from financial investments</b>	<b>82.5</b>	<b>66.6</b>	<b>100.4</b>
Investment management expenses	(3.1)	(3.9)	(7.3)
	<b>79.4</b>	<b>62.7</b>	<b>93.1</b>

### 4 Other income

	6 months ended 30 June 2017 \$m	6 months ended 30 June 2016 \$m	Year to 31 December 2016 \$m
Commission income	10.6	9.6	15.5
Profit commissions	4.5	5.2	14.9
Agency fees	1.1	1.0	2.0
Other income <sup>1</sup>	0.8	-	0.3
	<b>17.0</b>	<b>15.8</b>	<b>32.7</b>

1. In May 2017 the group sold its Australian accident and health business, previously included in the PAC segment, to Blend Insurance Solutions PTY Limited, a Sydney-based Lloyd's service company, for total consideration of \$0.8m. The gain on the disposal of \$0.8m is included in the other income line.

### 5 Finance costs

	6 months ended 30 June 2017 \$m	6 months ended 30 June 2016 \$m	Year to 31 December 2016 \$m
Interest expense	10.9	7.3	15.2
	<b>10.9</b>	<b>7.3</b>	<b>15.2</b>



## 6 Earnings per share

	6 months ended 30 June 2017	6 months ended 30 June 2016	Year to 31 December 2016
Basic (cents)	25.3	25.1	48.6
Diluted (cents)	24.6	24.3	47.3
Basic (pence)	20.2	17.3	35.5
Diluted (pence)	19.7	16.8	34.5

### Basic

Basic earnings per share are calculated by dividing profit after income tax of \$131.7m (30 June 2016: \$128.8m; 31 December 2016: \$251.0m) by the weighted average number of shares in issue during the six months of 520.8m (30 June 2016: 513.7m; 31 December 2016: 516.3m). The shares held in the Employee Share Options Plan (ESOP) of 5.0m (30 June 2016: 6.8m; 31 December 2016: 6.1m) have been excluded from the calculation until such time as they vest unconditionally with the employees.

### Diluted

Diluted earnings per share are calculated by dividing profit after income tax of \$131.7m (30 June 2016: \$128.8m; 31 December 2016: \$251.0m) by the adjusted weighted average number of shares of 535.5m (30 June 2016: 529.3m; 31 December 2016: 531.0m). The adjusted weighted average number of shares assumes conversion of dilutive potential ordinary shares, being shares from the SAYE (Save As You Earn), retention and deferred share schemes. The shares held in the ESOP of 5.0m (30 June 2016: 6.8m; 31 December 2016: 6.1m) have been excluded from the calculation until such time as they vest unconditionally with the employees.

## 7 Dividends

A first interim dividend of 3.7p per ordinary share (2016: 3.5p) is payable in respect of the six months to 30 June 2017. These financial statements do not provide for this dividend as a liability.

The first interim dividend will be payable on 31 August 2017 to shareholders registered at 5.00pm on 4 August 2017.

A second interim dividend of 7.0p per ordinary share and a special dividend of 10.0p was paid on 29 March 2017 to shareholders registered at 5.00pm on 3 March 2017 in respect of the six months ended 31 December 2016.

## Notes to the interim financial statements *continued*

### 8 Income tax expense

	6 months ended 30 June 2017 \$m	6 months ended 30 June 2016 \$m	Year to 31 December 2016 \$m
<b>Current tax expense</b>			
Current year	32.6	25.2	37.1
Prior year adjustments	0.8	1.7	2.1
	<b>33.4</b>	<b>26.9</b>	<b>39.2</b>
<b>Deferred tax expense</b>			
Origination and reversal of temporary differences	(6.0)	(4.6)	2.1
Impact of change in UK tax rates	-	(0.2)	(0.8)
Prior year adjustments	(0.4)	(0.7)	1.7
	<b>(6.4)</b>	<b>(5.5)</b>	<b>3.0</b>
<b>Income tax expense</b>	<b>27.0</b>	<b>21.4</b>	<b>42.2</b>

	6 months ended 30 June 2017 \$m	6 months ended 30 June 2017 %	6 months ended 30 June 2016 \$m	6 months ended 30 June 2016 %	Year to 31 December 2016 \$m	Year to 31 December 2016 %
<b>Profit before tax</b>	<b>158.7</b>		<b>150.2</b>		<b>293.2</b>	
Tax calculated at the weighted average of statutory tax rates	26.7	16.8	22.8	15.2	43.6	14.9
<b>Effects of:</b>						
Non-deductible expenses	0.6	0.4	1.2	0.8	1.8	0.6
Non-taxable gains on foreign exchange	(0.7)	(0.4)	(3.4)	(2.3)	(5.6)	(1.9)
Tax relief on share based payments – current and future years	-	-	-	-	(0.6)	(0.2)
Under/(over) provided in prior years	0.4	0.2	1.0	0.7	3.8	1.3
Change in UK tax rates <sup>1</sup>	-	-	(0.2)	(0.1)	(0.8)	(0.3)
<b>Tax charge for the period</b>	<b>27.0</b>	<b>17.0</b>	<b>21.4</b>	<b>14.3</b>	<b>42.2</b>	<b>14.4</b>

1 The Finance Act 2015, which provides for reduction in the UK Corporation tax rate down to 19% effective from 1 April 2017 was substantively enacted on 26 October 2015. The Finance Act 2016, which provides for reduction in the UK Corporation tax rate down to 17% effective from 1 April 2020 was substantively enacted on 6 September 2016. These rate reductions to 19% and 17% will reduce the company's future current tax charge and have been reflected in the calculation of the deferred tax balance as at 30 June 2017.

The group has assessed the potential impact of diverted profits tax (DPT) following the enactment of new legislation in April 2015 and is of the view that no liability arises. The ultimate outcome may differ and any profits that did fall within scope of DPT would potentially be taxed at a rate of 25% rather than 12.5% (the current rate of tax on corporate earning in Ireland).

## 9 Financial assets and liabilities

	30 June 2017 \$m	30 June 2016 \$m	31 December 2016 \$m
<b>Financial assets at fair value</b>			
Government issued	908.2	1,170.4	1,180.0
Quasi-government	28.7	121.7	62.0
Supranational	18.1	0.9	19.5
Asset backed securities	11.3	3.6	4.6
Senior secured loans	91.3	83.3	96.2
Corporate bonds			
– Investment grade	2,322.1	1,928.8	2,158.0
– High yield	106.0	118.7	97.1
<b>Total fixed and floating rate debt securities</b>	<b>3,485.7</b>	<b>3,427.4</b>	<b>3,617.4</b>
Equity linked funds	167.0	98.9	116.3
Hedge funds	344.0	295.4	317.1
Illiquid credit assets	168.4	125.8	132.4
<b>Total capital growth</b>	<b>679.4</b>	<b>520.1</b>	<b>565.8</b>
<b>Total financial investments at fair value through statement of profit or loss</b>	<b>4,165.1</b>	<b>3,947.5</b>	<b>4,183.2</b>
Derivative financial assets	12.6	5.3	12.2
<b>Total financial assets at fair value</b>	<b>4,177.7</b>	<b>3,952.8</b>	<b>4,195.4</b>

Quasi-government securities include securities which are issued by government agencies or entities supported by government guarantees. Supranational securities are issued by institutions sponsored by more than one sovereign issuer. Asset backed securities are backed by financial assets, including corporate loans. Investment grade corporate bonds include debt instruments of corporate issuers rated BBB-/Baa3 or better by one or more major rating agency and high yield corporate bonds have credit ratings below this level. Equity linked funds are investment vehicles which are predominantly exposed to equity securities. Our illiquid credit assets are described in further detail below. The fair value of these assets at 30 June 2017 excludes an unfunded commitment of \$59.6m (30 June 2016: \$91.0m).

	30 June 2017 \$m	30 June 2016 \$m	31 December 2016 \$m
<b>The amount expected to mature before and after one year are:</b>			
Within one year	981.2	1,069.4	937.2
After one year	2,517.1	2,363.3	2,692.4
<b>Total</b>	<b>3,498.3</b>	<b>3,432.7</b>	<b>3,629.6</b>

Our capital growth assets have no defined maturity dates and have thus been excluded from the above maturity table. However, 92% (30 June 2016: 89%) of equity linked funds could be liquidated within two weeks and 8% within six months, 80% (30 June 2016: 96%) of hedge fund assets within six months and the remaining 20% (30 June 2016: 4%) of hedge fund assets within 18 months. Illiquid credit assets are not readily realisable and principal will be returned over the life of these assets, which may be up to ten years.

## Notes to the interim financial statements *continued*

### 9 Financial assets and liabilities *continued*

	30 June 2017 \$m	30 June 2016 \$m	31 December 2016 \$m
<b>Financial liabilities</b>			
Retail bond	95.5	99.8	94.7
Subordinated debt	18.0	18.0	18.0
Tier 2 subordinated debt (2026) – recalled in 2016	–	103.0	–
Tier 2 subordinated debt (2026) – issued in 2016	248.4	–	248.3
Derivative financial liabilities	18.3	11.6	2.8
<b>Total financial liabilities</b>	<b>380.2</b>	<b>232.4</b>	<b>363.8</b>

	30 June 2017 \$m	30 June 2016 \$m	31 December 2016 \$m
The amount expected to mature before and after one year are:			
Within one year	18.3	114.6	2.8
After one year	361.9	117.8	361.0
<b>Total</b>	<b>380.2</b>	<b>232.4</b>	<b>363.8</b>

#### Fair value measurement

The table on page 24 summarises financial assets carried at fair value using a valuation hierarchy that reflects the significance of the inputs used in making the measurements. The fair value hierarchy has the following levels:

Level 1 – Valuations based on quoted prices in active markets for identical instruments. An active market is a market in which transactions for the instrument occur with sufficient frequency and volume on an ongoing basis such that quoted prices reflect prices at which an orderly transaction would take place between market participants at the measurement date. Included within level 1 are bonds and treasury bills of government and government agencies which are measured based on quoted prices.

Level 2 – Valuations based on quoted prices in markets that are not active, or based on pricing models for which significant inputs can be corroborated by observable market data (e.g. interest rates, exchange rates). Included within level 2 are government bonds and treasury bills which are not actively traded, corporate bonds, asset backed securities and mortgage-backed securities.

Level 3 – Valuations based on inputs that are unobservable or for which there is limited market activity against which to measure fair value.

The availability of financial data can vary for different financial assets and is affected by a wide variety of factors, including the type of financial instrument, whether it is new and not yet established in the marketplace, and other characteristics specific to each transaction. To the extent that valuation is based on models or inputs that are unobservable in the market, the determination of fair value requires more judgement. Accordingly the degree of judgement exercised by management in determining fair value is greatest for instruments classified in level 3. The group uses prices and inputs that are current as of the measurement date for valuation of these instruments.

If the inputs used to measure the fair value of an asset or a liability could be categorised in different levels of the fair value hierarchy, then the fair value measurement is categorised in its entirety in the same level of the fair value hierarchy as the lowest level input that is significant to the entire measurement.

#### Level 2 investments

The group has an established control framework and valuation policy with respect to the measurement of fair values. For the group's level 2 debt securities our fund administrator obtains the prices used in the valuation from independent pricing vendors such as Bloomberg, Standard & Poor's, Reuters, Markit and International Data Corporation. The independent pricing vendors derive an evaluated price from observable market inputs. The market inputs include trade data, two-sided markets, institutional bids, comparable trades, dealer quotes, news media, and other relevant market data. These inputs are verified in their pricing engines and calibrated with the pricing models to calculate spread to benchmarks, as well as other pricing assumptions such as Weighted Average life (WM), Discount Margins (DM), Default rates, and recovery and prepayments assumptions for mortgage securities. While such valuations are sensitive to estimates, it is believed that changing one or more of the assumptions to reasonably possible alternative assumptions would not change the fair value significantly.

## 9 Financial assets and liabilities *continued*

### *Level 2 investments continued*

The group records the unadjusted price provided and validates the price through various tolerance checks, such as comparison with prices provided by investment custodians and investment managers, to assess the reasonableness and accuracy of the price to be used to value each security. In the rare case that a price fails the tolerance test, it is escalated and discussed internally. We would not normally override a price retrospectively, but we would work with the administrator and pricing vendor to investigate the difference. We also review our valuation policy on a regular basis to ensure it is fit for purpose. As at 30 June 2017, no adjustments have been made to the prices obtained from the independent administrator.

For our hedge funds and equity linked funds, pricing and valuation is undertaken by independent administrators in accordance with the valuation policy of each fund. Regulated equity linked fund prices are published on a daily or weekly basis via Bloomberg and other market data providers such as Reuters. Hedge fund values are communicated by the independent administrators to all investors via monthly investor statements.

Additional information is obtained from fund managers relating to the underlying assets within individual hedge funds and equity linked funds. This shows that 67% (30 June 2016: 73%, 31 December 2016: 77%) of these underlying assets were level 1 and the remainder level 2. This enables us to categorise our hedge fund and equity linked fund investments as level 2.

Prior to any new hedge fund investment, extensive due diligence is undertaken on each fund to ensure that pricing and valuation is undertaken by an independent administrator and that each fund's valuation policy is appropriate for the financial instruments the manager will be employing to execute the investment strategy. Fund liquidity terms are reviewed prior to the execution of any investment to ensure that there is no mismatch between the liquidity of the underlying fund assets and the liquidity terms offered to fund investors.

### *Level 3 investments*

The level 3 categorisation applies only to some of our illiquid credit investments. These are generally participations in limited partnership vehicles which hold diverse, typically illiquid, investments. While these funds provide full transparency of their underlying investments, the investments themselves are in many cases private and unquoted, and are therefore classified as level 3 investments.

Valuation inputs can be subjective and may include a discount rate applied to the investment based on market factors and expectations of future cash flows, the nature of the investment, local market conditions, trading values on public exchanges for comparable securities, current and projected operating performance relative to benchmarks, financial condition, and financing transactions subsequent to the acquisition of the investment.

We take the following steps to ensure accurate valuation of these level 3 assets: a substantial part of the pre-investment due diligence process is dedicated to a comprehensive review of each fund's valuation policy and the internal controls of the manager. In addition to this, confirmation that the investment reaches a minimum set of standards relating to the independence of service providers, corporate governance, and transparency is sought prior to approval. Post investment, unaudited capital statements confirming the fair value of the Limited Partner interests are received and reviewed on a quarterly (or more frequent) basis. Audited financial statements are received on an annual basis, with the valuation of each transaction being confirmed.

## Notes to the interim financial statements *continued*

### 9 Financial assets and liabilities *continued*

The following table shows the fair values of financial assets and financial liabilities, including their levels in the fair value hierarchy.

30 June 2017	Level 1 \$m	Level 2 \$m	Level 3 \$m	Total \$m
<b>Financial assets measured at fair value</b>				
Government issued	908.2	-	-	908.2
Quasi-government	28.5	0.2	-	28.7
Supranational	18.1	-	-	18.1
Asset backed securities	-	11.3	-	11.3
Senior secured loans	-	91.3	-	91.3
Corporate bonds				
- Investment grade	17.7	2,304.4	-	2,322.1
- High yield	-	106.0	-	106.0
Equity linked funds	-	167.0	-	167.0
Hedge funds	-	344.0	-	344.0
Illiquid credit assets	-	-	168.4	168.4
Derivative financial assets	12.6	-	-	12.6
<b>Total financial assets measured at fair value</b>	<b>985.1</b>	<b>3,024.2</b>	<b>168.4</b>	<b>4,177.7</b>
<b>Financial liabilities measured at fair value</b>				
Derivative financial liabilities	18.3	-	-	18.3
<b>Financial liabilities not measured at fair value</b>				
Retail bond	-	101.3	-	101.3
Tier 2 subordinated debt (2026) – issued in 2016	-	256.8	-	256.8
<b>Total financial liabilities not measured at fair value</b>	<b>-</b>	<b>358.1</b>	<b>-</b>	<b>358.1</b>
<b>30 June 2016</b>				
	Level 1 \$m	Level 2 \$m	Level 3 \$m	Total \$m
<b>Financial assets measured at fair value</b>				
Government issued	1,170.4	-	-	1,170.4
Quasi-government	121.7	-	-	121.7
Supranational	0.9	-	-	0.9
Asset backed securities	2.0	1.6	-	3.6
Senior secured loans	-	83.3	-	83.3
Corporate bonds				
- Investment grade	39.3	1,889.5	-	1,928.8
- High yield	-	118.7	-	118.7
Equity linked funds	-	98.9	-	98.9
Hedge funds	-	295.4	-	295.4
Illiquid credit assets	-	8.7	117.1	125.8
Derivative financial assets	5.3	-	-	5.3
<b>Total financial assets measured at fair value</b>	<b>1,339.6</b>	<b>2,496.1</b>	<b>117.1</b>	<b>3,952.8</b>
<b>Financial liabilities measured at fair value</b>				
Derivative financial liabilities	11.6	-	-	11.6
<b>Financial liabilities not measured at fair value</b>				
Retail bond	-	102.8	-	102.8
Tier 2 subordinated debt	-	101.2	-	101.2
<b>Total financial liabilities not measured at fair value</b>	<b>-</b>	<b>204.0</b>	<b>-</b>	<b>204.0</b>



## 9 Financial assets and liabilities *continued*

31 December 2016	Level 1 \$m	Level 2 \$m	Level 3 \$m	Total \$m
<b>Financial assets measured at fair value</b>				
Government issued	1,180.0	-	-	1,180.0
Quasi-government	62.0	-	-	62.0
Supranational	19.5	-	-	19.5
Asset backed securities	-	4.6	-	4.6
Senior secured loans	-	96.2	-	96.2
Corporate bonds				
- Investment grade	45.0	2,113.0	-	2,158.0
- High yield	-	97.1	-	97.1
Equity linked funds	-	116.3	-	116.3
Hedge funds	-	317.1	-	317.1
Illiquid credit assets	-	6.3	126.1	132.4
Derivative financial assets	12.2	-	-	12.2
<b>Total financial assets measured at fair value</b>	<b>1,318.7</b>	<b>2,750.6</b>	<b>126.1</b>	<b>4,195.4</b>
<b>Financial liabilities measured at fair value</b>				
Derivative financial liabilities	2.8	-	-	2.8
<b>Financial liabilities not measured at fair value</b>				
Retail bond	-	100.8	-	100.8
Tier 2 subordinated debt (2026) – issued in 2016	-	253.3	-	253.3
<b>Total financial liabilities not measured at fair value</b>	<b>-</b>	<b>354.1</b>	<b>-</b>	<b>354.1</b>

The table above does not include financial assets and liabilities that are, in accordance with the group's accounting policies, recorded at amortised cost, if the carrying amount of these financial assets and liabilities approximates their fair values at the reporting date.

### *Unconsolidated structured entities*

A structured entity is defined as an entity that has been designed so that voting or similar rights are not the dominant factor in deciding who controls the entity, such as when any voting rights relate to administrative tasks only, or when the relevant activities are directed by means of contractual arrangements.

As part of its standard investment activities the group holds investments in high yield bond funds, asset backed securities, equity linked funds, hedge funds and illiquid credit assets which in accordance with IFRS 12 are classified as unconsolidated structured entities. The group does not sponsor any of the unconsolidated structured entities. The assets classified as unconsolidated structured entities are held at fair value on the balance sheet.

The investments comprising the group's unconsolidated structured entities are as follows:

	30 June 2017 \$m	30 June 2016 \$m	31 December 2016 \$m
High yield bond funds	106.0	40.7	97.1
Asset backed securities	11.3	3.6	4.6
Equity linked funds	167.0	99.4	116.3
Hedge funds	344.0	294.9	317.1
Illiquid credit assets	168.4	125.8	132.4
<b>Investments through unconsolidated structured entities</b>	<b>796.7</b>	<b>564.4</b>	<b>667.5</b>

## Notes to the interim financial statements *continued*

### 9 Financial assets and liabilities *continued*

#### *Transfers and level 3 investment reconciliations*

There were no transfers in either direction between level 1, level 2 and level 3 in either 2016 or 2017.

The table below shows a reconciliation from the opening balances to the closing balances of level 3 fair values. The total net unrealised gains recognised in the \$9.8m (30 June 2016: \$4.7m) are included in the net investment income number of \$79.4m (30 June 2016: \$62.7m) shown in the condensed consolidated statement of profit or loss.

	30 June 2017 \$m	30 June 2016 \$m	31 December 2016 \$m
As at 1 January	126.1	89.7	89.7
Purchases	41.0	36.2	47.9
Sales	(8.5)	(13.5)	(21.6)
Total net unrealised gains recognised in profit or loss	9.8	4.7	10.1
<b>As at period end</b>	<b>168.4</b>	<b>117.1</b>	<b>126.1</b>

The currency exposures of our financial assets held at fair value are detailed below:

30 June 2017	UK £ \$m	CAD \$ \$m	EURO € \$m	Subtotal \$m	US \$ \$m	Total \$m
<b>Financial assets at fair value</b>						
Fixed and floating rate debt securities	13.4	160.3	-	173.7	3,312.0	3,485.7
Equity linked funds	-	-	35.7	35.7	131.3	167.0
Hedge funds	-	-	-	-	344.0	344.0
Illiquid credit assets	-	-	10.9	10.9	157.5	168.4
Derivative financial assets	-	-	-	-	12.6	12.6
<b>Total</b>	<b>13.4</b>	<b>160.3</b>	<b>46.6</b>	<b>220.3</b>	<b>3,957.4</b>	<b>4,177.7</b>

30 June 2016	UK £ \$m	CAD \$ \$m	EURO € \$m	Subtotal \$m	US \$ \$m	Total \$m
<b>Financial assets at fair value</b>						
Fixed and floating rate debt securities	219.1	121.6	118.6	459.3	2,968.1	3,427.4
Equity linked funds	-	-	28.5	28.5	70.4	98.9
Hedge funds	-	-	-	-	295.4	295.4
Illiquid credit assets	-	-	10.3	10.3	115.5	125.8
Derivative financial assets	-	-	-	-	5.3	5.3
<b>Total</b>	<b>219.1</b>	<b>121.6</b>	<b>157.4</b>	<b>498.1</b>	<b>3,454.7</b>	<b>3,952.8</b>

31 December 2016	UK £ \$m	CAD \$ \$m	EURO € \$m	Subtotal \$m	US \$ \$m	Total \$m
<b>Financial assets at fair value</b>						
Fixed and floating rate debt securities	140.1	169.2	-	309.3	3,308.1	3,617.4
Equity linked funds	-	-	29.7	29.7	86.6	116.3
Hedge funds	-	-	-	-	317.1	317.1
Illiquid credit assets	-	-	8.1	8.1	124.3	132.4
Derivative financial assets	-	-	-	-	12.2	12.2
<b>Total</b>	<b>140.1</b>	<b>169.2</b>	<b>37.8</b>	<b>347.1</b>	<b>3,848.3</b>	<b>4,195.4</b>

The above qualitative and quantitative disclosures, along with the risk management disclosure included in note 2 of the annual report for the year ending 31 December 2016, enables more comprehensive evaluation of Beazley's exposure to risks arising from financial instruments.

---

## 10 Cash and cash equivalents

	30 June 2017 \$m	30 June 2016 \$m	31 December 2016 \$m
Cash at bank and in hand	417.2	303.6	374.6
Short-term deposits and highly liquid investments	44.2	138.2	132.6
	<b>461.4</b>	<b>441.8</b>	<b>507.2</b>

Total cash and cash equivalents include \$49.0m (31 December 2016: \$44.5m) held in Lloyd's Singapore trust accounts. These funds are only available for use by the group to meet local claim and expense obligations.

## 11 Insurance claims

The loss development tables below provide information about historical claims development by the five segments – marine, political, accident and contingency, property, reinsurance and specialty lines. The tables are by underwriting year which in our view provides the most transparent reserving basis. We have supplied tables for both ultimate gross claims ratios and ultimate net claims ratios.

The top part of the table illustrates how the group's estimated claims ratio for each underwriting year has changed at successive year-ends.

While the information in the tables provide a historical perspective on the adequacy of the claims liabilities established in previous years, users of these financial statements are cautioned against extrapolating past redundancies or deficiencies on current claims liabilities. The group believes that the estimates of total claims liabilities as at 30 June 2017 are adequate. However, due to inherent uncertainties in the reserving process, it cannot be assured that such balances will ultimately prove to be adequate.

## Notes to the interim financial statements *continued*

### 11 Insurance claims *continued*

Gross ultimate claims	2007 <sup>ae</sup>	2008	2009	2010	2011	2012	2013	2014	2015	2016	2017	Total
	%	%	%	%	%	%	%	%	%	%	%	
<b>Marine</b>												
12 months	69.3	54.3	50.5	54.6	55.9	56.5	57.5	56.7	59.5			
24 months	65.5	50.9	49.7	47.4	46.3	52.0	46.8	54.0				
36 months	59.4	44.1	44.0	39.0	34.7	44.4	47.1					
48 months	63.3	40.6	42.3	33.7	32.2	42.7						
60 months	62.9	40.3	40.4	35.3	31.4							
72 months	59.2	48.6	40.1	31.6								
84 months	55.4	47.8	42.1									
96 months	54.8	49.1										
108 months	51.7											
Position at 30 June 2017	58.4	49.0	40.7	31.1	31.4	42.2	46.3	48.7	61.4			
<b>Political, accident &amp; contingency</b>												
12 months	57.4	58.3	57.7	57.5	60.0	59.2	59.2	59.8	61.3			
24 months	71.7	43.4	44.8	44.5	54.4	49.4	51.2	58.8				
36 months	75.9	37.9	39.0	44.2	51.3	44.9	47.0					
48 months	89.4	33.7	32.5	39.4	48.9	43.9						
60 months	73.8	29.3	31.5	37.6	45.8							
72 months	62.5	25.0	30.3	35.5								
84 months	59.2	25.1	29.4									
96 months	59.8	25.2										
108 months	59.0											
Position at 30 June 2017	58.3	25.3	29.9	35.2	45.6	43.2	46.1	57.9	58.3			
<b>Property</b>												
12 months	70.5	53.6	57.8	58.2	55.4	55.1	53.2	54.9	58.9			
24 months	65.1	41.5	60.3	50.3	47.4	49.2	47.7	49.0				
36 months	64.1	36.3	58.3	47.8	39.7	45.8	41.3					
48 months	62.0	35.2	55.6	46.0	36.7	45.8						
60 months	60.5	34.1	52.9	45.1	36.1							
72 months	59.4	33.1	51.9	44.0								
84 months	58.3	32.5	51.0									
96 months	57.6	32.1										
108 months	57.3											
Position at 30 June 2017	57.3	32.1	50.8	43.9	35.9	45.6	40.6	48.1	58.6			

## 11 Insurance claims *continued*

	2007 <sup>ae</sup>	2008	2009	2010	2011	2012	2013	2014	2015	2016	2017	Total
Gross ultimate claims	%	%	%	%	%	%	%	%	%	%	%	
<b>Reinsurance</b>												
12 months	59.8	60.7	68.0	79.2	62.9	58.8	61.5	65.8	67.5			
24 months	54.4	48.0	141.0	77.7	37.5	45.0	33.6	33.7				
36 months	44.7	39.9	127.8	69.6	32.1	42.4	31.0					
48 months	41.2	39.4	120.1	65.9	31.2	41.1						
60 months	40.9	35.2	123.5	63.1	31.3							
72 months	41.0	32.3	122.2	62.9								
84 months	40.3	31.7	122.2									
96 months	40.0	31.7										
108 months	39.9											
Position at 30 June 2017	39.9	31.7	122.2	61.4	31.3	40.2	30.7	26.8	67.5			
<b>Specialty lines</b>												
12 months	72.0	72.5	73.7	75.4	73.9	73.4	68.5	67.4	65.3			
24 months	71.8	72.4	73.8	75.5	74.0	73.2	68.4	67.8				
36 months	71.8	71.6	72.8	76.5	72.1	72.9	65.0					
48 months	72.0	71.3	73.3	75.5	70.2	69.3						
60 months	71.4	71.6	69.5	74.1	67.3							
72 months	71.8	68.6	69.7	69.4								
84 months	70.1	69.7	69.4									
96 months	73.5	70.3										
108 months	72.9											
Position at 30 June 2017	73.2	70.6	69.4	68.8	66.1	67.6	63.6	65.2	65.1			
<b>Total</b>												
12 months	69.1	62.8	64.4	67.2	64.6	63.8	62.2	62.7	63.3			
24 months	68.1	56.9	71.4	62.8	58.2	59.3	55.8	58.4				
36 months	66.5	53.1	67.4	60.4	53.2	56.4	52.5					
48 months	67.7	51.6	65.3	57.8	51.0	54.3						
60 months	65.7	50.7	63.0	56.9	49.1							
72 months	64.1	49.8	62.6	53.7								
84 months	62.1	49.9	62.5									
96 months	63.6	50.3										
108 months	62.6											
Position at 30 June 2017	63.8	50.4	62.3	53.2	48.6	53.3	51.4	55.6	63.1			
Total ultimate losses (\$m)	5,416.5	1,195.2	1,059.5	1,292.8	1,020.4	945.5	1,151.1	1,197.6	1,364.1	1,594.1	1,726.8	17,963.6
Less paid claims (\$m)	(5,168.0)	(1,025.5)	(845.9)	(1,141.6)	(857.7)	(753.3)	(778.8)	(656.3)	(472.3)	(247.4)	(17.8)	(11,964.6)
Less unearned portion of ultimate losses (\$m)	-	-	-	-	-	-	-	-	(6.3)	(235.9)	(1,512.8)	(1,755.0)
<b>Gross claims liabilities (100% level) (\$m)</b>	<b>248.5</b>	<b>169.7</b>	<b>213.6</b>	<b>151.2</b>	<b>162.7</b>	<b>192.2</b>	<b>372.3</b>	<b>541.3</b>	<b>885.5</b>	<b>1,110.8</b>	<b>196.2</b>	<b>4,244.0</b>
Less unaligned share (\$m)	(47.7)	(24.6)	(33.6)	(30.5)	(31.6)	(41.2)	(61.8)	(82.8)	(134.1)	(165.9)	(30.2)	(684.0)
<b>Gross claims liabilities, group share (\$m)</b>	<b>200.8</b>	<b>145.1</b>	<b>180.0</b>	<b>120.7</b>	<b>131.1</b>	<b>151.0</b>	<b>310.5</b>	<b>458.5</b>	<b>751.4</b>	<b>944.9</b>	<b>166.0</b>	<b>3,560.0</b>

## Notes to the interim financial statements *continued*

### 11 Insurance claims *continued*

Net ultimate claims	2007 <sup>ae</sup>	2008	2009	2010	2011	2012	2013	2014	2015	2016	2017	Total
	%	%	%	%	%	%	%	%	%	%	%	
<b>Marine</b>												
12 months	61.3	53.2	52.1	55.5	55.4	56.0	56.4	56.7	56.7			
24 months	56.9	47.5	49.2	47.6	46.1	53.1	48.4	52.5				
36 months	50.5	38.8	44.7	38.5	37.4	47.4	46.5					
48 months	47.3	35.1	42.6	34.3	35.0	45.8						
60 months	46.8	34.8	41.0	35.4	33.9							
72 months	46.2	38.4	40.1	32.1								
84 months	45.0	37.7	42.3									
96 months	44.5	37.0										
108 months	44.9											
Position at 30 June 2017	47.9	36.9	40.8	31.6	33.9	45.7	46.3	49.4	59.6			
<b>Political, accident &amp; contingency</b>												
12 months	55.8	56.3	54.4	54.8	58.6	58.6	56.9	57.5	60.2			
24 months	79.6	41.5	43.6	45.1	52.5	50.9	49.8	56.1				
36 months	78.8	36.4	39.6	45.4	49.9	47.4	45.0					
48 months	81.6	33.6	33.3	42.2	46.9	44.8						
60 months	71.0	29.7	32.3	40.2	43.7							
72 months	60.2	26.2	31.2	38.1								
84 months	56.6	26.3	29.7									
96 months	56.9	26.3										
108 months	56.6											
Position at 30 June 2017	56.0	26.5	30.5	37.7	43.6	43.8	45.7	55.0	58.1			
<b>Property</b>												
12 months	66.9	53.3	58.8	60.2	58.6	56.7	54.5	55.0	57.6			
24 months	66.7	47.2	65.0	57.6	52.9	56.3	51.1	50.2				
36 months	64.7	43.7	65.6	53.5	45.9	52.3	44.2					
48 months	63.5	41.5	59.7	50.3	41.2	50.1						
60 months	62.4	40.8	57.6	48.9	40.7							
72 months	61.0	39.6	56.5	47.8								
84 months	60.3	39.1	56.0									
96 months	59.3	38.8										
108 months	59.1											
Position at 30 June 2017	59.0	38.8	55.8	47.8	40.5	50.0	42.8	49.2	57.5			

## 11 Insurance claims *continued*

Net ultimate claims	2007 <sup>ae</sup>	2008	2009	2010	2011	2012	2013	2014	2015	2016	2017	Total
	%	%	%	%	%	%	%	%	%	%	%	
<b>Reinsurance</b>												
12 months		68.7	55.5	76.7	90.1	67.0	56.7	58.8	61.4	60.9		
24 months		61.5	52.6	125.1	87.9	45.5	51.7	37.4	34.2			
36 months		51.1	46.8	115.2	80.4	39.2	48.3	33.6				
48 months		48.8	46.1	109.1	74.9	37.8	46.8					
60 months		48.3	41.2	119.0	72.6	37.8						
72 months		48.6	37.9	113.1	72.6							
84 months		47.4	37.1	113.1								
96 months		47.1	37.1									
108 months		47.1										
Position at 30 June 2017		47.1	37.1	113.1	70.8	37.8	45.7	33.2	25.7	60.9		
<b>Specialty lines</b>												
12 months		70.1	69.5	70.9	72.4	71.0	69.5	66.0	63.5	62.9		
24 months		70.0	69.3	71.0	72.4	70.6	69.0	65.9	63.9			
36 months		69.8	68.7	70.5	71.7	68.7	68.5	63.6				
48 months		68.5	65.8	69.5	69.5	65.7	63.5					
60 months		67.8	65.7	68.9	70.1	63.8						
72 months		67.7	64.9	69.0	68.8							
84 months		67.7	65.5	68.8								
96 months		69.9	65.4									
108 months		69.7										
Position at 30 June 2017		69.5	65.3	68.8	68.4	63.4	62.2	60.5	61.6	62.6		
<b>Total</b>												
12 months		66.7	60.6	64.2	67.0	64.0	62.2	60.6	60.1	60.8		
24 months		67.1	56.5	68.4	63.6	58.3	60.1	56.1	56.5			
36 months		64.6	52.8	66.0	60.1	53.7	57.3	52.5				
48 months		63.4	50.3	62.9	57.0	50.7	54.2					
60 months		61.8	49.3	62.8	56.7	49.3						
72 months		60.6	48.6	61.8	55.1							
84 months		59.9	48.5	61.8								
96 months		60.6	48.3									
108 months		60.5										
Position at 30 June 2017		60.9	48.3	61.6	54.6	49.1	53.4	50.9	54.0	60.8		
Total ultimate losses (\$m)	3,638.8	938.9	778.6	1,051.0	856.5	828.2	966.7	1,008.3	1,089.4	1,281.1	1,415.9	13,853.4
Less paid claims (\$m)	(3,414.0)	(835.5)	(684.3)	(937.3)	(741.0)	(666.1)	(671.8)	(567.5)	(407.7)	(222.1)	(17.4)	(9,164.7)
Less unearned portion of ultimate losses (\$m)	-	-	-	-	-	-	-	-	(2.9)	(228.2)	(1,258.9)	(1,490.0)
<b>Net claims liabilities (100% level) (\$m)</b>	<b>224.8</b>	<b>103.4</b>	<b>94.3</b>	<b>113.7</b>	<b>115.5</b>	<b>162.1</b>	<b>294.9</b>	<b>440.8</b>	<b>678.8</b>	<b>830.8</b>	<b>139.6</b>	<b>3,198.7</b>
Less unaligned share (\$m)	(31.1)	(17.1)	(19.1)	(23.2)	(24.9)	(32.2)	(50.5)	(67.0)	(103.3)	(123.1)	(21.3)	(512.8)
<b>Net claims liabilities, group share (\$m)</b>	<b>193.7</b>	<b>86.3</b>	<b>75.2</b>	<b>90.5</b>	<b>90.6</b>	<b>129.9</b>	<b>244.4</b>	<b>373.8</b>	<b>575.5</b>	<b>707.7</b>	<b>118.3</b>	<b>2,685.9</b>

### 11 Insurance claims *continued*

#### *Analysis of movements in loss development tables*

We have updated our loss development tables to show the interim ultimate loss ratios as at 30 June 2017 for each underwriting year. As such, care should be taken when comparing these half year movements to the full year movements shown within the body of the table.

#### *Marine*

The 2008 underwriting year saw a deterioration following adverse development on a specific claim within the energy book. Conversely, the 2010 year saw a release as a result of a favourable settlement. Catastrophe margin has been released from the 2015 underwriting year, however adverse claims experience across hull, aviation and UK marine in the 2016 underwriting year has resulted in an increase.

#### *Political, accident & contingency*

Recoveries in respect of political claims have driven small releases across prior underwriting years. The 2014 year saw a net strengthening following a deterioration on a trade credit claim within the political book. Some catastrophe margin has been released from the stand alone terrorism book, from the 2016 underwriting year.

#### *Property*

The remaining catastrophe margin was released from the 2015 underwriting year, reflecting the continued benign catastrophe experience and the run off of exposure. Small releases were seen across prior years from a number of classes.

#### *Reinsurance*

Catastrophe margin has been released from the 2015 underwriting year following continued benign experience. Small releases from prior years reflect favourable developments observed on underlying claims.

#### *Specialty lines*

Releases from the 2012 and 2013 underwriting years reflect favourable developments in the long tail book, whilst in the 2014 underwriting year, releases have been made from the cyber classes.



## 11 Insurance claims *continued*

### Claims releases

The table below analyses our net insurance claims between current year claims and adjustments to prior year net claims reserves. These have been broken down by segment and period.

The net of reinsurance claims release on 2016 and prior underwriting years has risen to \$83.4m (2016: \$77.4m). The releases are the result of both generally favourable development and recoveries on specific claims.

The movements shown on 2014 and earlier are absolute claim movements and are not impacted by any current year movements on premium on those underwriting years.

	Marine \$m	Political, accident & contingency \$m	Property \$m	Reinsurance \$m	Specialty lines \$m	Total \$m
<b>6 months ended 30 June 2017</b>						
Current year	63.8	48.8	82.1	35.2	292.4	522.3
Prior year						
- 2014 and earlier	(0.8)	2.9	(4.1)	(2.9)	(37.5)	(42.4)
- 2015 underwriting year	(5.6)	(1.7)	(3.0)	(11.3)	(20.9)	(42.5)
- 2016 underwriting year	3.1	(1.2)	(0.1)	(0.1)	(0.2)	1.5
	(3.3)	-	(7.2)	(14.3)	(58.6)	(83.4)
<b>Net insurance claims</b>	<b>60.5</b>	<b>48.8</b>	<b>74.9</b>	<b>20.9</b>	<b>233.8</b>	<b>438.9</b>

	Marine \$m	Political, accident & contingency \$m	Property \$m	Reinsurance \$m	Specialty lines \$m	Total \$m
<b>6 months ended 30 June 2016</b>						
Current year	56.3	58.5	77.3	35.0	286.5	513.6
Prior year						
- 2013 and earlier	5.8	(7.0)	(5.0)	(1.1)	(22.8)	(30.1)
- 2014 underwriting year	(2.0)	(1.7)	(9.3)	(3.7)	(11.7)	(28.4)
- 2015 underwriting year	(3.2)	1.3	(3.3)	(12.7)	(1.0)	(18.9)
	0.6	(7.4)	(17.6)	(17.5)	(35.5)	(77.4)
<b>Net insurance claims</b>	<b>56.9</b>	<b>51.1</b>	<b>59.7</b>	<b>17.5</b>	<b>251.0</b>	<b>436.2</b>

	Marine \$m	Political, accident & contingency \$m	Property \$m	Reinsurance \$m	Specialty lines \$m	Total \$m
<b>Year to 31 December 2016</b>						
Current year	114.8	127.0	152.0	72.5	570.0	1,036.3
Prior year						
- 2013 and earlier	(7.0)	(17.7)	(11.6)	-	(52.0)	(88.3)
- 2014 underwriting year	(4.1)	(9.0)	(18.4)	(4.2)	(17.0)	(52.7)
- 2015 underwriting year	(4.8)	(0.5)	(6.8)	(28.1)	0.5	(39.7)
	(15.9)	(27.2)	(36.8)	(32.3)	(68.5)	(180.7)
<b>Net insurance claims</b>	<b>98.9</b>	<b>99.8</b>	<b>115.2</b>	<b>40.2</b>	<b>501.5</b>	<b>855.6</b>

## Notes to the interim financial statements *continued*

### 12 Related party transactions

The nature of the related party transactions of the group are consistent in nature and scope with those disclosed in note 30 of the group's consolidated financial statements for the year ended 31 December 2016.

### 13 Foreign exchange rates

The group used the following exchange rates to translate foreign currency assets, liabilities, income and expenses into US dollars, being the group's presentation currency:

	6 months ended 30 June 2017	6 months ended 30 June 2016	Year to 31 December 2016
<b>Average</b>			
Pound sterling	0.80	0.69	0.73
Canadian dollar	1.34	1.34	1.34
Euro	0.94	0.90	0.91
<b>Spot</b>			
Pound sterling	0.78	0.75	0.79
Canadian dollar	1.33	1.30	1.31
Euro	0.89	0.90	0.94

### 14 Subsequent events

Since the reporting date, Beazley has sold its share in one of its associates, Equinox Global Limited. The effect of the transaction is still to be fully confirmed but will have an immaterial effect on the financial position of the group.

### 15 Business combinations

#### Acquisition of business portfolio

In January 2017 Beazley Furlonge Holdings Limited, an intermediate holding company within the group, set up a direct 100% subsidiary, 1104980 BC Limited, in Canada. The principal activity of 1104980 BC Limited was to act as an intermediate holding company within the group. This subsidiary acquired 100% of the share capital of a Canadian coverholder, Creechurch International Underwriters Limited (now Beazley Canada Limited), on 3 February 2017. In June 2017 1104980 BC Limited and Beazley Canada Limited amalgamated under the name of Beazley Canada Limited.

The acquisition secured a strategic platform for specialty lines and Beazley's expansion in Canada. It also allowed us to write more business through increased line size and launching new specialist products through the acquiree's distribution channels. The acquisition was achieved in one stage. The total amount of consideration paid was \$33.8m. Total amount of consideration represents cash and no contingent consideration was offered.

The acquisition had the following effect on the group's assets and liabilities:

	Carrying value at acquisition \$m	Fair value adjustment \$m	Fair value on completion \$m
<b>Net assets acquired (provisional)</b>			
Intangible assets – renewal rights	–	34.4	34.4
Fixed assets	0.1	–	0.1
Cash and cash equivalents	2.6	–	2.6
Other receivables	0.3	–	0.3
Other payables	(1.0)	–	(1.0)
Deferred tax liability	–	(2.6)	(2.6)
<b>Estimated value of net assets acquired</b>	<b>2.0</b>	<b>31.8</b>	<b>33.8</b>
Intangible assets – goodwill			–
<b>Consideration paid</b>			<b>33.8</b>

The effect of the acquisition on the group's consolidated statement of profit or loss in the current period was less than \$1.0m. No material costs related to the acquisition were incurred by the group.

# Responsibility statement of the directors in respect of the interim report

We confirm that to the best of our knowledge:

- the condensed consolidated financial statements have been prepared in accordance with IAS 34 Interim Financial Reporting as adopted by the EU;
- the interim management report includes a fair review of the information required by:
  - (a) DTR 4.2.7R of the Disclosure and Transparency Rules, being an indication of important events that have occurred during the first six months of the financial year and their impact on the condensed set of financial statements; and a description of the principal risks and uncertainties for the remaining six months of the year; and
  - (b) DTR 4.2.8R of the Disclosure and Transparency Rules, being related party transactions that have taken place in the first six months of the current financial year and that have materially affected the financial position or performance of the entity during that six months; and any changes in the related party transactions described in the last annual report that could do so.

**Martin Bride**  
*Finance director*

*20 July 2017*

# Independent review report to Beazley plc

## Conclusion

We have been engaged by the company to review the condensed set of financial statements in the half-yearly financial report for the six months ended 30 June 2017 which comprises condensed consolidated financial statement of profit or loss, condensed statement of comprehensive income, condensed consolidated statement of changes in equity, condensed consolidated statement of financial position, condensed consolidated statement of cash flows and the related explanatory notes.

Based on our review, nothing has come to our attention that causes us to believe that the condensed set of financial statements in the half-yearly financial report for the six months ended 30 June 2017 is not prepared, in all material respects, in accordance with IAS 34 Interim Financial Reporting as adopted by the EU and the Disclosure Guidance and Transparency Rules ('the DTR') of the UK's Financial Conduct Authority ('the UK FCA').

## Scope of review

We conducted our review in accordance with International Standard on Review Engagements (UK and Ireland) 2410 Review of Interim Financial Information Performed by the Independent Auditor of the Entity issued by the Auditing Practices Board for use in the UK. A review of interim financial information consists of making enquiries, primarily of persons responsible for financial and accounting matters, and applying analytical and other review procedures. We read the other information contained in the half-yearly financial report and consider whether it contains any apparent misstatements or material inconsistencies with the information in the condensed set of financial statements.

A review is substantially less in scope than an audit conducted in accordance with International Standards on Auditing (UK) and consequently does not enable us to obtain assurance that we would become aware of all significant matters that might be identified in an audit. Accordingly, we do not express an audit opinion.

## Directors' responsibilities

The half-yearly financial report is the responsibility of, and has been approved by, the directors. The directors are responsible for preparing the half-yearly financial report in accordance with the DTR of the UK FCA.

As disclosed in Note 1, the annual financial statements of the group are prepared in accordance with International Financial Reporting Standards as adopted by the EU. The directors are responsible for preparing the condensed set of financial statements included in the half-yearly financial report in accordance with IAS 34 as adopted by the EU.

## Our responsibility

Our responsibility is to express to the company a conclusion on the condensed set of financial statements in the half-yearly financial report based on our review.

## The purpose of our review work and to whom we owe our responsibilities

This report is made solely to the company in accordance with the terms of our engagement to assist the company in meeting the requirements of the DTR of the UK FCA. Our review has been undertaken so that we might state to the company those matters we are required to state to it in this report and for no other purpose. To the fullest extent permitted by law, we do not accept or assume responsibility to anyone other than the company for our review work, for this report, or for the conclusions we have reached.

## Daniel Cazeaux

*For and on behalf of  
KPMG LLP,  
Chartered Accountants  
15 Canada Square  
London  
E14 5GL*

*20 July 2017*

# Glossary

## Aggregates/aggregations

Accumulations of insurance loss exposures which result from underwriting multiple risks that are exposed to common causes of loss.

## Aggregate excess of loss

The reinsurer indemnifies an insurance company (the reinsured) for an aggregate (or cumulative) amount of losses in excess of a specified aggregate amount.

## A.M. Best

A.M. Best is a worldwide insurance-rating and information agency whose ratings are recognised as an ideal benchmark for assessing the financial strength of insurance related organisations, following a rigorous quantitative and qualitative analysis of a company's balance sheet strength, operating performance and business profile.

## Binding authority

A contracted agreement between a managing agent and a coverholder under which the coverholder is authorised to enter into contracts of insurance for the account of the members of the syndicate concerned, subject to specified terms and conditions.

## Capacity

This is the maximum amount of premiums that can be accepted by a syndicate. Capacity also refers to the amount of insurance coverage allocated to a particular policyholder or in the marketplace in general.

## Capital growth assets

These are assets that do not pay a regular income and target an increase in value over the long term. They will typically have a higher risk and volatility than that of the core portfolio. Currently these are the hedge funds, equity linked funds and illiquid credit assets.

## Catastrophe reinsurance

A form of excess of loss reinsurance which, subject to a specified limit, indemnifies the reinsured company for the amount of loss in excess of a specified retention with respect to an accumulation of losses resulting from a catastrophic event or series of events.

## Claims

Demand by an insured for indemnity under an insurance contract.

## Claims ratio

Ratio, in percentage terms, of net insurance claims to net earned premiums. The calculation is performed excluding the impact of foreign exchange. As at 30 June 2017, this ratio was 49% (30 June 2016: 51%; 31 December 2016: 48%). This represented claims of \$438.9m (30 June 2016: \$436.2m; 31 December 2016: \$855.6m) divided by net earned premiums of \$886.7m (30 June 2016: \$861.4m; 31 December 2016: \$1,768.2m).

## Combined ratio

Ratio, in percentage terms, of the sum of net insurance claims, expenses for acquisition of insurance contracts and administrative expenses to net earned premiums. This is also the sum of the expense ratio and the claims ratio. The calculation is performed excluding the impact of foreign exchange. At 30 June 2017, this ratio was 90% (30 June 2016: 90%; 31 December 2016: 89%). This represents the sum of net insurance claims of \$438.9m (30 June 2016: \$436.2m; 31 December 2016: \$855.6m), expenses for acquisition of insurance contracts of \$241.5m (30 June 2016: \$219.6m; 31 December 2016: \$472.5m) and administrative expenses of \$121.7m (30 June 2016: \$117.2m; 31 December 2016: \$247.8m) to net earned premiums of \$886.7m (30 June 2016: 861.4m; 31 December 2016: \$1,768.2m). This is also the sum of the expense ratio 41% (30 June 2016: 39%; 31 December 2016: 41%) and the claims ratio 49% (30 June 2016: 51%; 31 December 2016: 48%).

## Coverholder/managing general agent

A firm either in the United Kingdom or overseas authorised by a managing agent under the terms of a binding authority to enter into contracts of insurance in the name of the members of the syndicate concerned, subject to certain written terms and conditions. A Lloyd's broker can act as a coverholder.

## Deferred acquisition costs (DAC)

Costs incurred for the acquisition or the renewal of insurance policies (e.g. brokerage, premium levy and staff related costs) which are capitalised and amortised over the term of the contracts.

## Earnings per share (EPS) – basic/diluted

Ratio, in pence and cents, calculated by dividing the consolidated profit after tax by the weighted average number of ordinary shares issued, excluding shares owned by the group. For calculating diluted earnings per share the number of shares and profit or loss for the year is adjusted for certain dilutive potential ordinary shares such as share options granted to employees.

## Economic Capital Requirement (ECR)

The capital required by a syndicate's members to support their underwriting. Calculated as the uSCR 'uplifted' by 35% to ensure capital is in place to support Lloyd's ratings and financial strength.

## Excess per risk reinsurance

A form of excess of loss reinsurance which, subject to a specified limit, indemnifies the reinsured company against the amount of loss in excess of a specified retention with respect to each risk involved in each loss.

### Expense ratio

Ratio, in percentage terms, of the sum of expenses for acquisition of insurance contracts and administrative expenses to net earned premiums. The calculation is performed excluding the impact of foreign exchange. At 30 June 2017, the expense ratio was 41% (30 June 2016: 39%; 31 December 2016: 41%). This represents the sum of expenses for acquisition of insurance contracts of \$241.5m (30 June 2016: \$219.6m; 31 December 2016: \$472.5m) and administrative expenses of \$121.7m (30 June 2016: \$117.2m; 31 December 2016: \$247.8m) to net earned premiums of \$886.7m (30 June 2016: \$861.4m; 31 December 2016: \$1,768.2m).

### Facultative reinsurance

A reinsurance risk that is placed by means of a separately negotiated contract as opposed to one that is ceded under a reinsurance treaty.

### Gross premiums written

Amounts payable by the insured, excluding any taxes or duties levied on the premium, including any brokerage and commission deducted by intermediaries.

### Hard market

An insurance market where prevalent prices are high, with restrictive terms and conditions offered by insurers.

### Horizontal limits

Reinsurance coverage limits for multiple events.

### Incurred but not reported (IBNR)

These are anticipated or likely claims that may result from an insured event although no claims have been reported so far.

### International Accounting Standards Board (IASB)

An independent accounting body responsible for developing IFRS (see below).

### International Accounting Standards (IAS)/International Financial Reporting Standards (IFRS)

Standards formulated by the IASB with the intention of achieving internationally comparable financial statements. Since 2002, the standards adopted by the IASB have been referred to as International Financial Reporting Standards (IFRS). Until existing standards are renamed, they continue to be referred to as International Accounting Standards (IAS).

### Lead underwriter

The underwriter of a syndicate who is responsible for setting the terms of an insurance or reinsurance contract that is subscribed by more than one syndicate and who generally has primary responsibility for handling any claims arising under such a contract.

### Line

The proportion of an insurance or reinsurance risk that is accepted by an underwriter or which an underwriter is willing to accept.

### Managing agent

A company that is permitted by Lloyd's to manage the underwriting of a syndicate.

### Managing general agent (MGA)

An insurance intermediary acting as an agent on behalf of an insurer.

### Medium tail

A type of insurance where the claims may be made a few years after the period of insurance has expired.

### Net assets per share

Ratio, in pence and cents, calculated by dividing the net assets (total equity) by the number of shares issued.

### Net premiums written

Net premiums written is equal to gross premiums written less outward reinsurance premiums written.

### Private enterprise

The private enterprise team offers specialised professional and general liability coverage supported by a high service proposition, focusing on meeting the needs of small businesses with assets up to \$35m and up to 500 employees.

### Provision for outstanding claims

Provision for claims that have already been incurred at the reporting date but have either not yet been reported or not yet been fully settled.

### Rate

The premium expressed as a percentage of the sum insured or limit of indemnity.

### Reinsurance special purpose syndicate

A special purpose syndicate (SPS) created to operate as a reinsurance 'sidecar' to Beazley's treaty account, capitalising on Beazley's position in the treaty reinsurance market.

### Reinsurance to close (RITC)

A reinsurance which closes a year of account by transferring the responsibility for discharging all the liabilities that attach to that year of account (and any year of account closed into that year), plus the right to buy any income due to the closing year of account, into an open year of account in return for a premium.

### Retention limits

Limits imposed upon underwriters for retention of exposures by the group after the application of reinsurance programmes.

### Retrocessional reinsurance

The reinsurance of the reinsurance account. It serves to 'lay off' risk.

### Return on equity (ROE)

Ratio, in percentage terms, calculated by dividing the consolidated profit after tax by the average daily total equity.

---

### Risk

This term may variously refer to:

- a) the possibility of some event occurring which causes injury or loss;
- b) the subject matter of an insurance or reinsurance contract; or
- c) an insured peril.

### Short tail

A type of insurance where claims are usually made during the term of the policy or shortly after the policy has expired. Property insurance is an example of short tail business.

### Sidecar special purpose syndicate

Specialty reinsurance company designed to provide additional capacity to a specific insurance company. It operates by purchasing a portion or all of a group of insurance policies, typically cat exposures. These companies have become quite prominent in the aftermath of Hurricane Katrina as a vehicle to add risk-bearing capacity, and for investors to participate in the potential profits resulting from sharp price increases.

### Soft market

An insurance market where prevalent prices are low, and terms and conditions offered by insurers are less restrictive.

### Solvency Capital Requirement on an ultimate basis (uSCR)

The capital requirement under Solvency II calculated by Beazley's internal model which captures the risk in respect of the planned underwriting for the prospective year of account in full covering ultimate adverse development and all exposures.

### Surplus lines insurer

An insurer that underwrites surplus lines insurance in the USA. Lloyd's underwriters are surplus lines insurers in all jurisdictions of the USA except Kentucky and the US Virgin Islands.

### Total shareholder return (TSR)

The increase in the share price plus the value of any first and second dividends paid and proposed during the year.

### Treaty reinsurance

A reinsurance contract under which the reinsurer agrees to offer and to accept all risks of certain size within a defined class.

### Unearned premiums reserve

The portion of premium income in the business year that is attributable to periods after the reporting date in the underwriting provisions.

# Company information

---

## Directors

Dennis Holt<sup>1</sup> (Chairman)  
George P Blunden<sup>1</sup>  
Martin L Bride (Finance director)  
Adrian P Cox  
Angela Crawford-Ingle<sup>1</sup>  
D Andrew Horton (Chief executive)  
Christine LaSala<sup>1</sup>  
Sir J Andrew Likierman<sup>1</sup>  
Neil P Maidment  
John P Sauerland<sup>1</sup>  
Robert A Stuchbery<sup>1</sup>  
Clive A Washbourn  
Catherine M Woods<sup>1</sup>

<sup>1</sup> Non-executive director

## Company secretary

Christine P Oldridge

## Registered office

Plantation Place South  
60 Great Tower Street  
London  
EC3R 5AD  
United Kingdom

## Registered number

09763575

## Auditors

KPMG LLP  
15 Canada Square  
London  
E14 5GL



---

If you have finished reading this report  
and no longer wish to keep it, please  
pass it on to other interested readers,  
return it to Beazley or recycle it. Thank you.

*Designed and produced by:  
Instinctif Partners [creative.instinctif.com](http://creative.instinctif.com)*

*Beazley online Interim 2017  
[www.reports.beazley.com/2017-interim](http://www.reports.beazley.com/2017-interim)*



## Beazley plc

Plantation Place South  
60 Great Tower Street  
London  
EC3R 5AD  
United Kingdom

Phone: +44 (0)20 7667 0623  
Fax: +44 (0)20 7674 7100

Registered number: 09763575

[www.beazley.com](http://www.beazley.com)

beazley

---